

1275335COM 3 Door Wall Cabinet

system™
build

Date of Purchase ___ / ___ / ___

Lot Number:

B341275335COM0

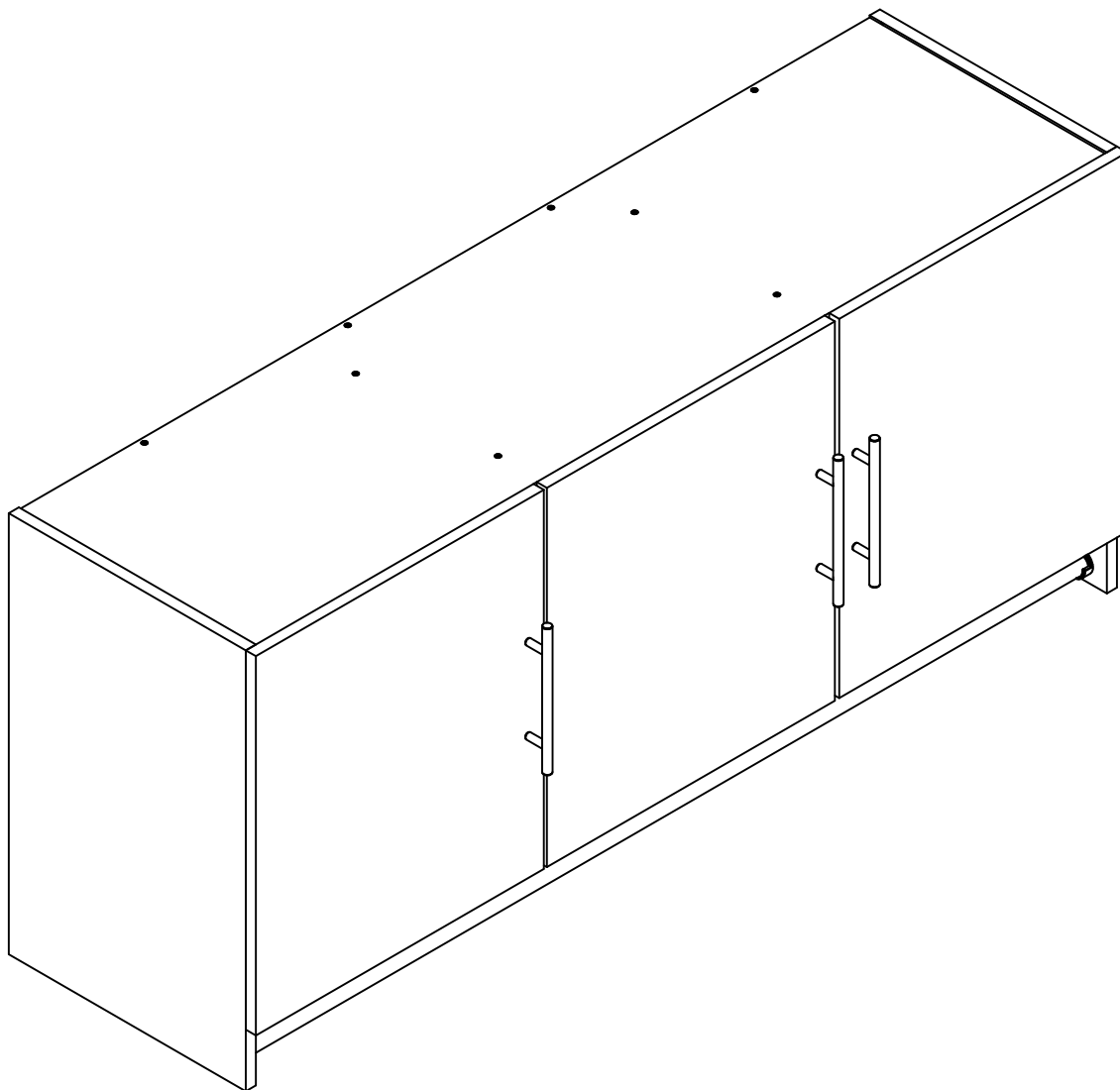

THIS INSTRUCTION BOOKLET CONTAINS **IMPORTANT** SAFETY INFORMATION. PLEASE READ AND KEEP FOR FUTURE REFERENCE.

Do Not Return This Product!

Contact our customer service team for help first.

Call: 1-866-452-4081 (toll free)

Monday-Friday 9am - 5pm CST

Visit: www.systembuild.com



WARNING

- Unit can tip over causing severe injury or death.
- Anchor unit to stud in wall (if instructed to).
- Do Not allow children to climb on unit.
- Put heavy items on lower shelves or drawers.

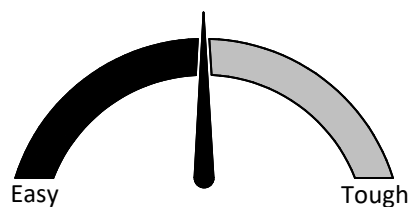

Assembly Difficulty Meter

For the latest information on SystemBuild products
follow us at Ameriwood Home



Contact Us!

Do NOT return this product!

Contact our friendly customer service team first for help.



Visit systembuild.com to view the limited warranty valid in the U.S. and Canada.

Assembly Tips



Helpful Hints

PEOPLE NEEDED FOR ASSEMBLY: 1-2

- Open your item in the area you plan to keep it to avoid excessive heavy lifting.
- Identify, sort and count the parts before attempting assembly.
- Compression dowels are lightly tapped in with a hammer.
- Slides are labeled with a **R** (right) and **L** (left) for proper placement.
- Make sure to always face the point on the top of the Cam Lock towards the outer edge.
- Use all the nails provided for the back panel and spread them out equally.
- Back panel must be used to make sure your unit is sturdy.
- Do NOT use harsh chemicals or abrasive cleaners on this item.
- Never push, pull, or drag your furniture.

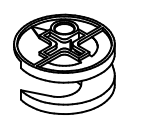

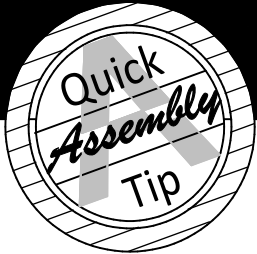

Before You Start

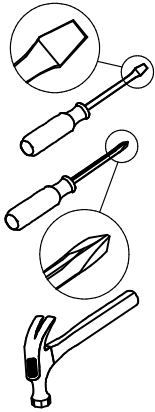

- ✓ Read through each step carefully and follow the proper order
- ✓ Separate and count all your parts and hardware
Parts are labeled on the surface or edge of the part
- ✓ Give yourself enough room for the assembly process
- ✓ Have the following tools: Flat Head Screwdriver, #2 Phillips Head Screwdriver and Hammer
- ✓ Caution: If using a power drill or power screwdriver for screwing, please be aware to slow down and stop when screw is tight. Failure to do so may result in stripping the screw.

Cam Lock Fastening System

This Cam Lock Fastening System will be used throughout the assembly process.

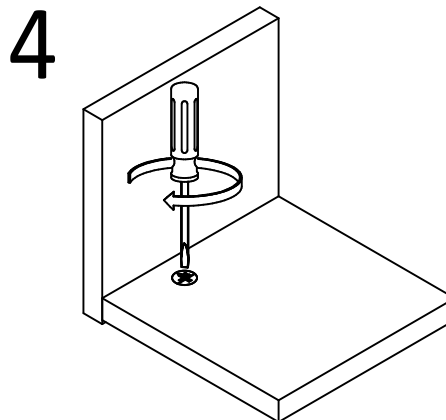
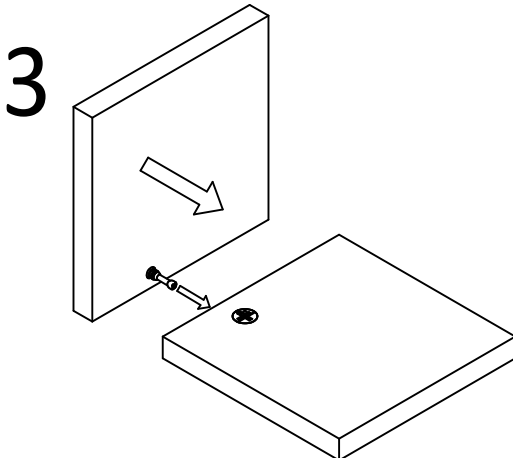
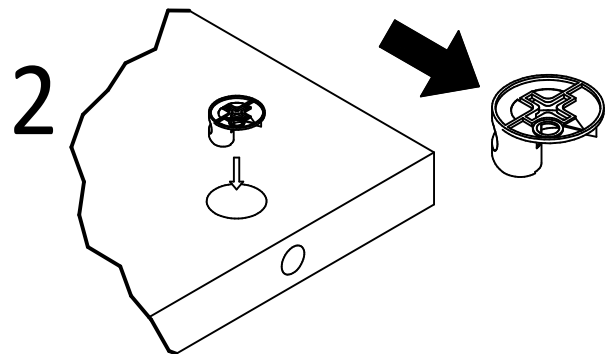
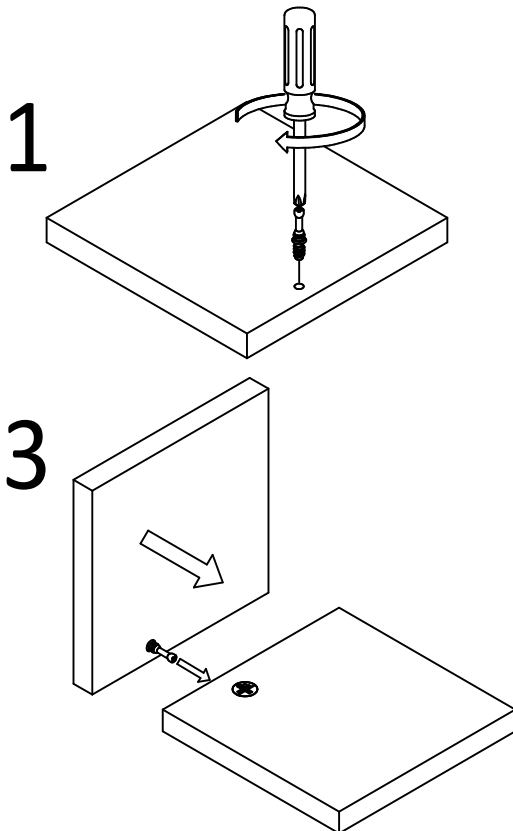

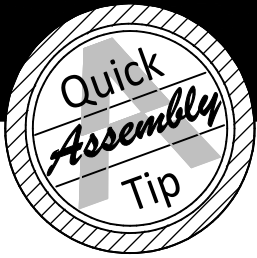

Before You Start

Please Note:
You may need to lightly tap the wood dowels into the holes during your assembly process.

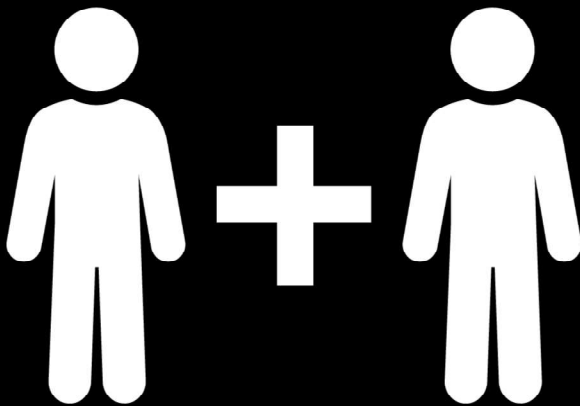
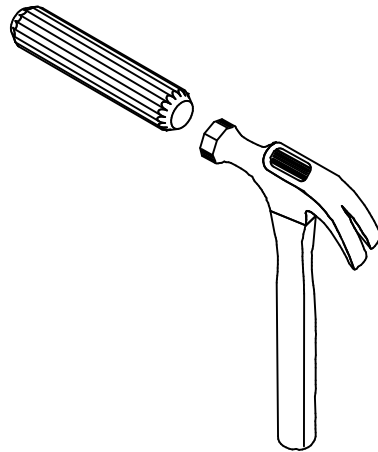

2 PEOPLE NEEDED FOR ASSEMBLY

**2 PERSONAS NECESITADAS
PARA LA ASAMBLEA**

**2 PERSONNES NÉCESSAIRES
POUR L'ASSEMBLAGE**

CAUTION: Failure to use 2 people for assembly could result in unit damage or personal injury.

PRECAUCIÓN: Si no se utilizan 2 personas para el ensamblaje, se pueden producir daños en la unidad o lesiones personales.

ATTENTION: Échec d'utiliser 2 personnes pour l'assemblage peut causer du dommage au meuble ou causer des blessures.

Board Identification

Not actual size

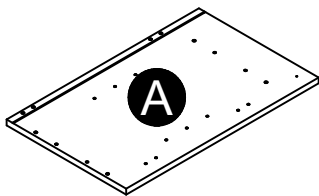

Left Panel
34056335010

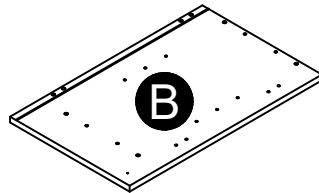

Right Panel
34056335020

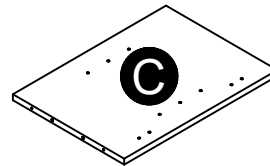

Left Partition
34056335030

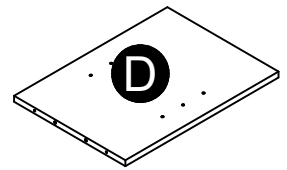

Right Partition
34056335040

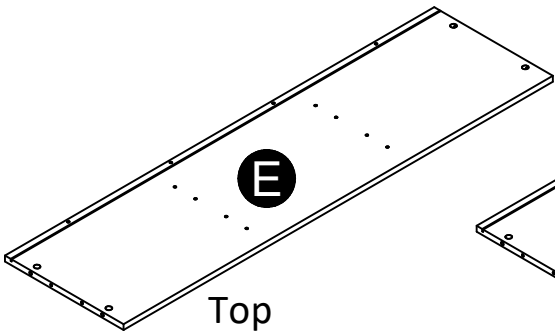

Top
34056335050

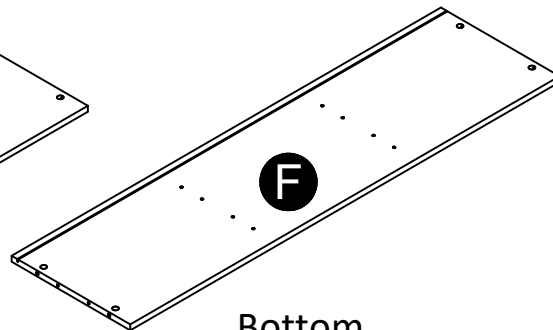

Bottom
34056335060

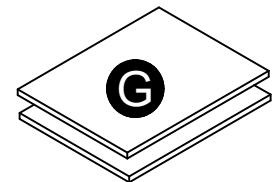

Side Adjustable Shelf (x2)
34056335070

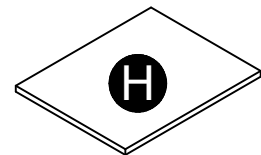

Center Adjustable Shelf
34056335080

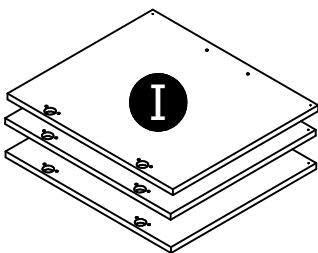

Door (x3)
31275335090

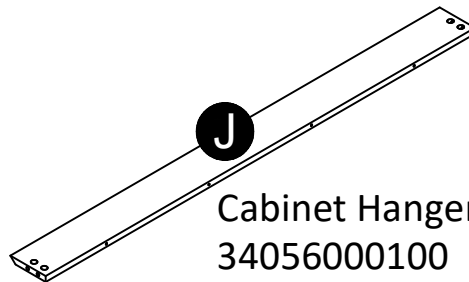

Cabinet Hanger
34056000100

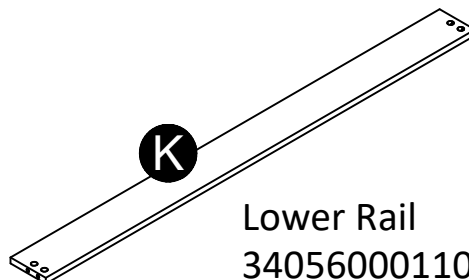

Lower Rail
34056000110

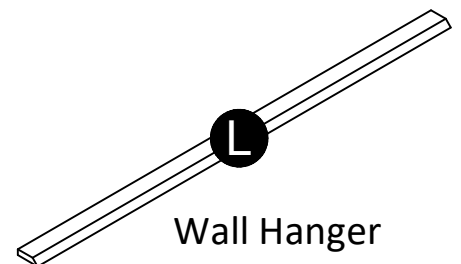

Wall Hanger
34056000120

Board Identification

Not actual size

This piece is paperboard construction. It is not made from wood, but is required for the assembly of your unit.

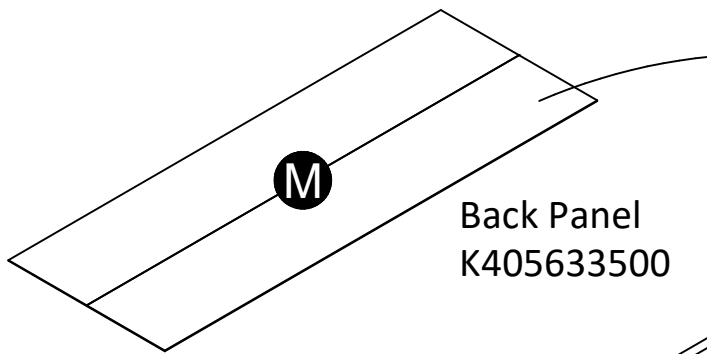

Back Panel
K405633500

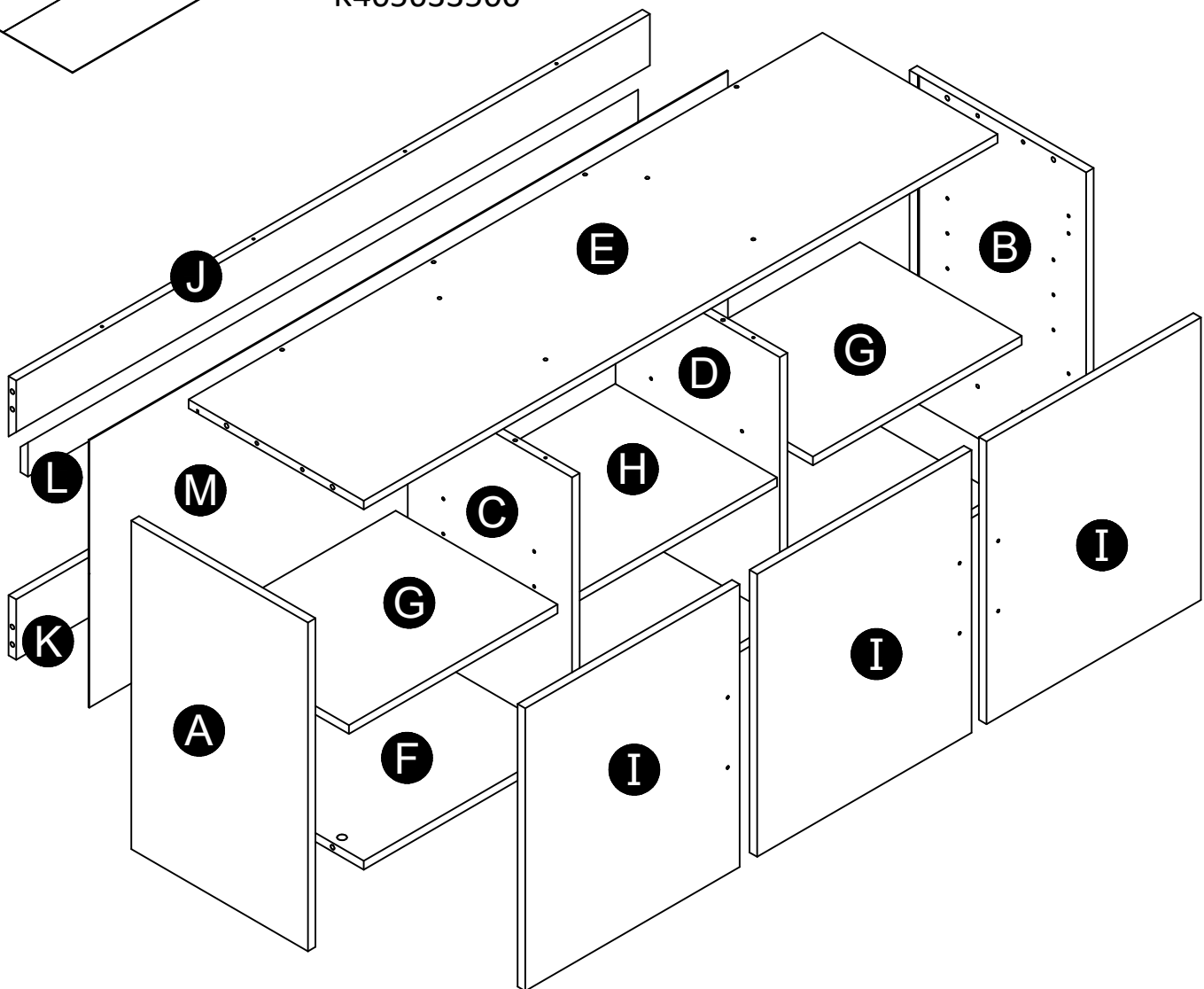

Part List

Actual Size

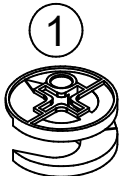

(x16)
#A22620
cam lock

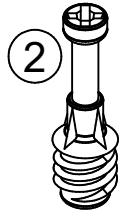

(x16)
#A22610
cam bolt

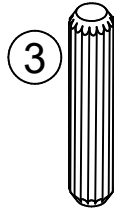

(x16)
#A21670
wood dowel

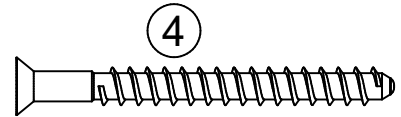

(x12)
#A23030
confirmat screw

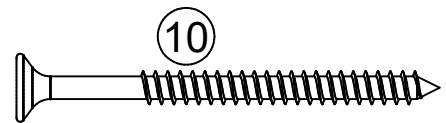

(x4)
#A13800
#8 x 2-1/4" screw

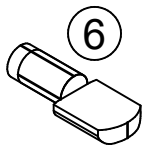

(x12)
#A80250
shelf support



(x2)
#A11080
7/16" screw

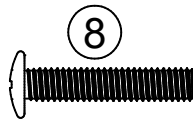

(x6)
#A17400
7/8" truss bolt



(x6)
#A89210
door pad

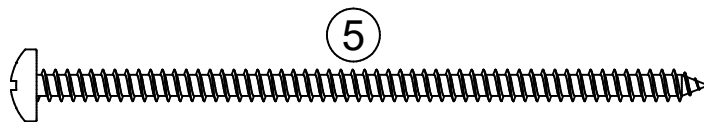

(x8)
#A13950
#8 x 3-1/2" screw

Not Actual Size



(x2)
9 -#A82020 (black)
12 -#A82010 (white)
rod bracket

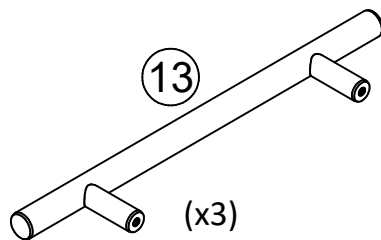

(x3)
#A52680
handle

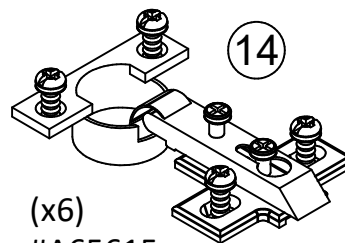

(x6)
#A65615
hinge

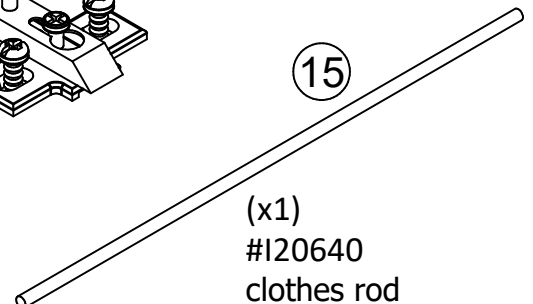

(x1)
#I20640
clothes rod

STEP 1

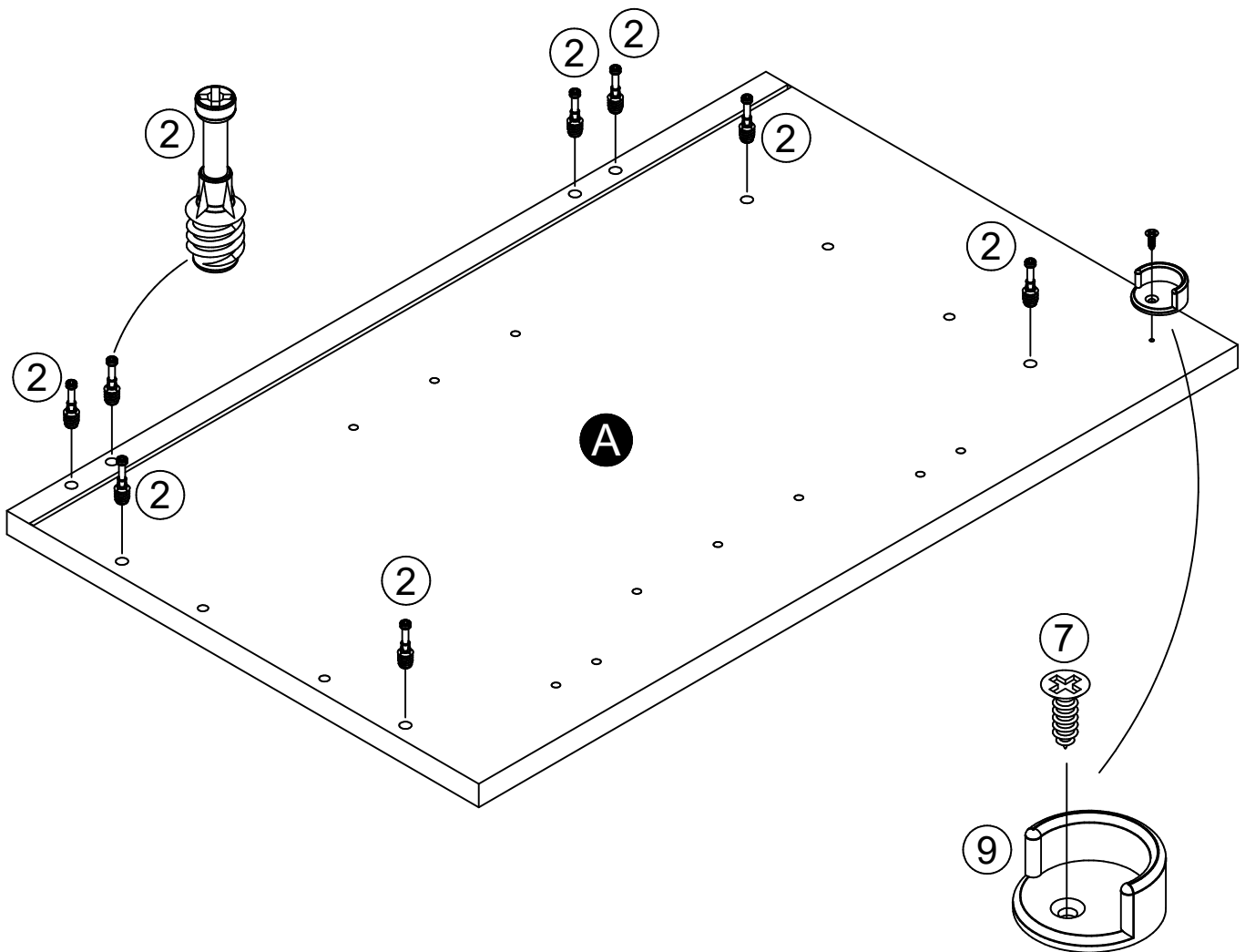
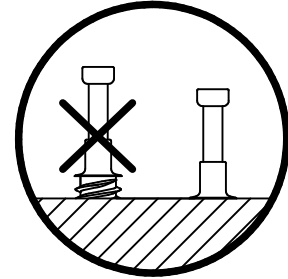
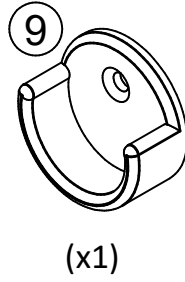
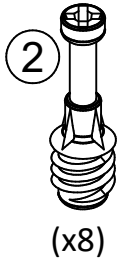
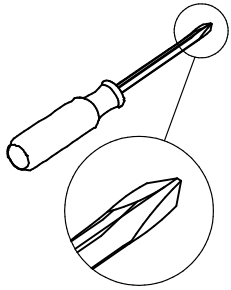

STEP 2

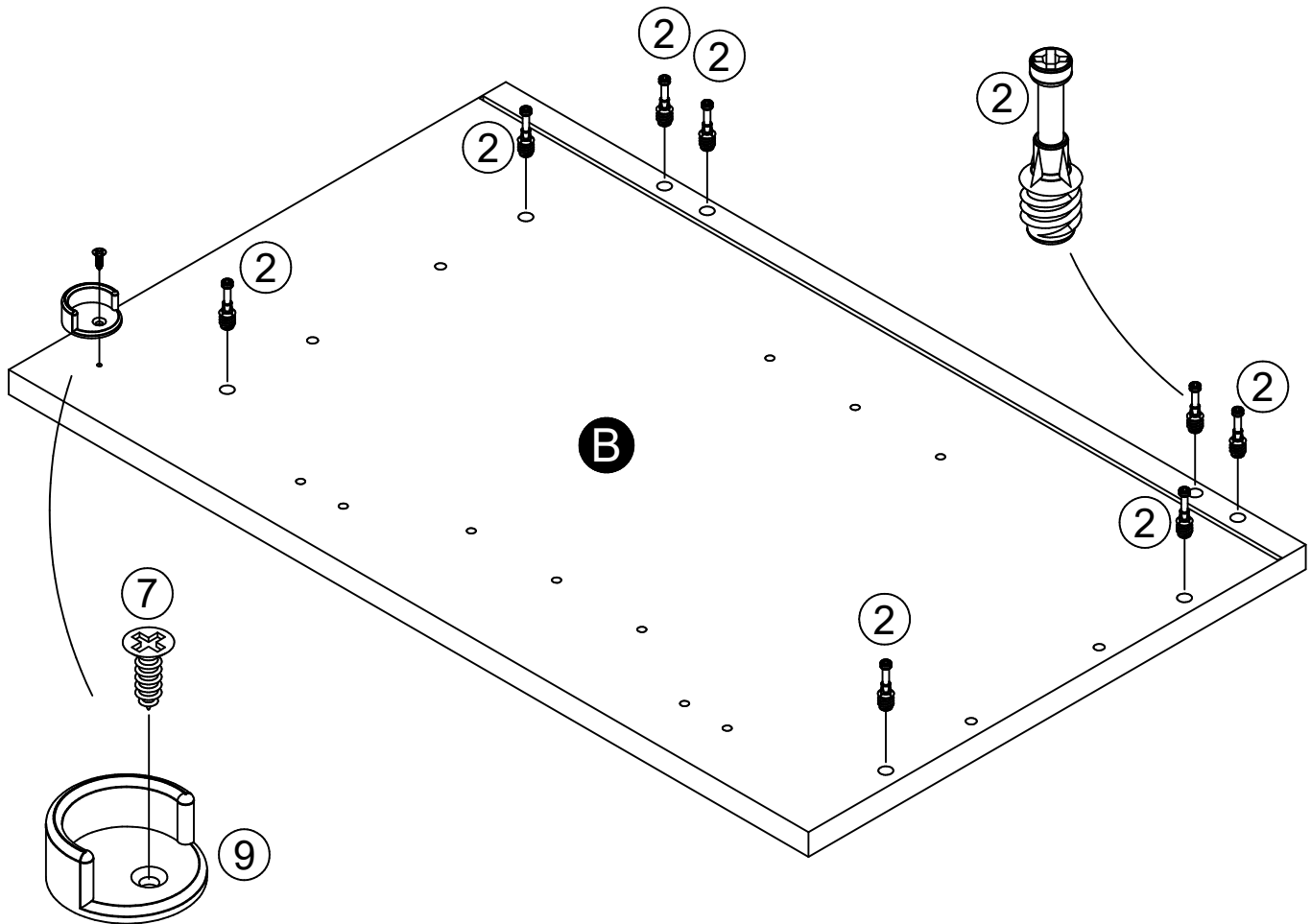
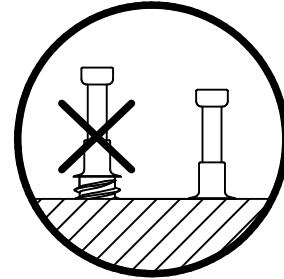
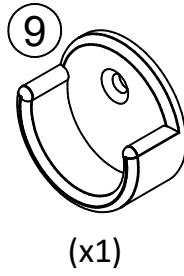
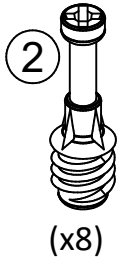
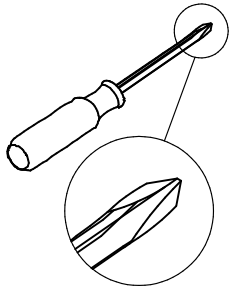

STEP 3

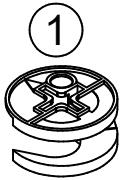

(x4)

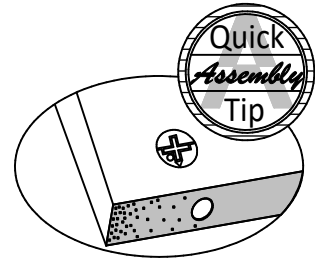

Proper orientation of CAM LOCK

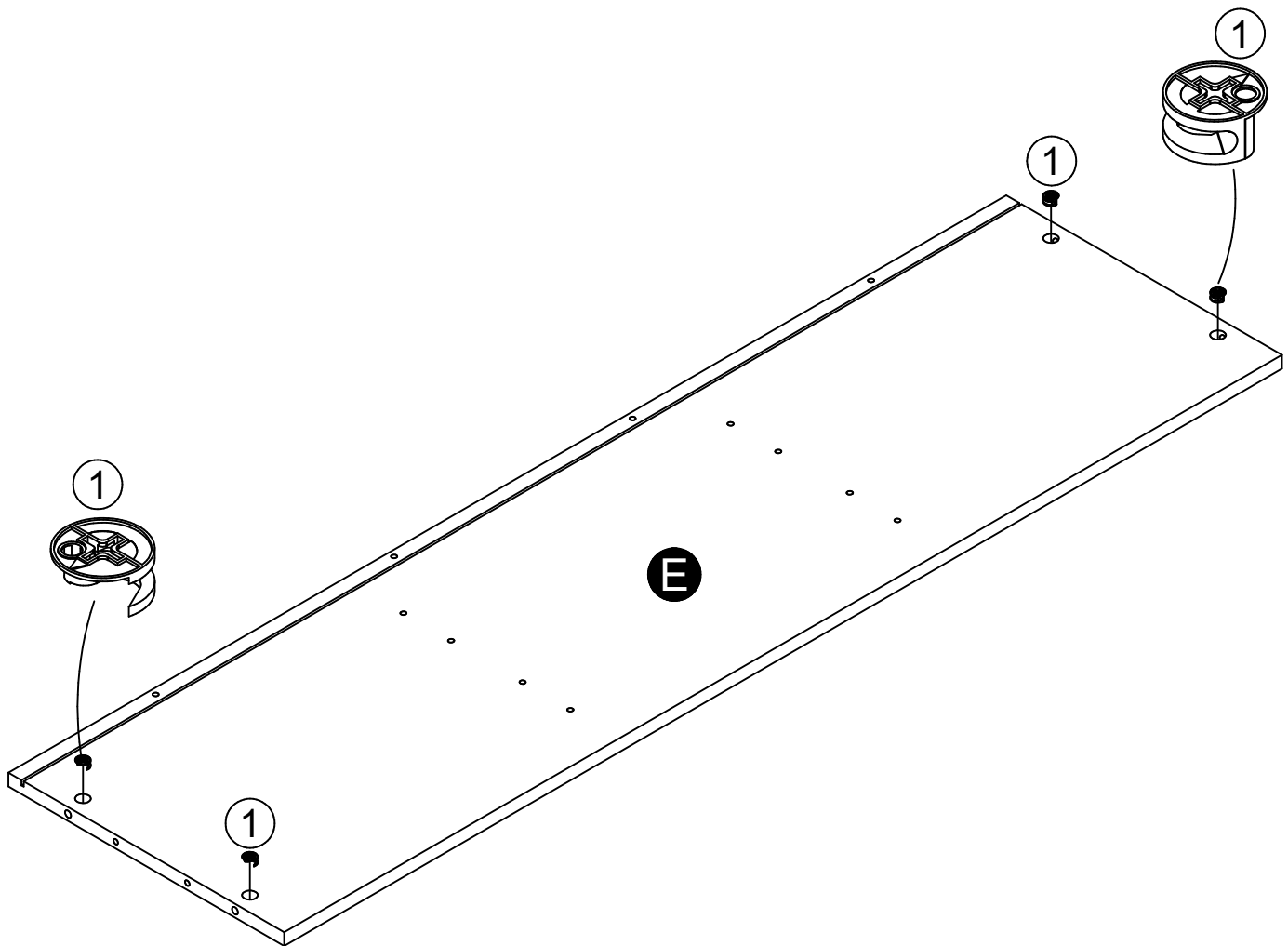

STEP 4

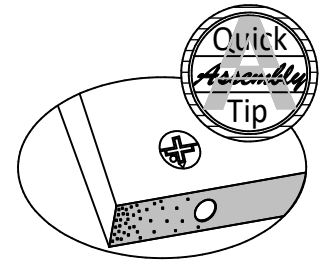
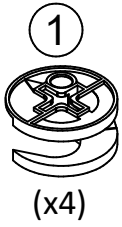

Proper orientation of CAM LOCK

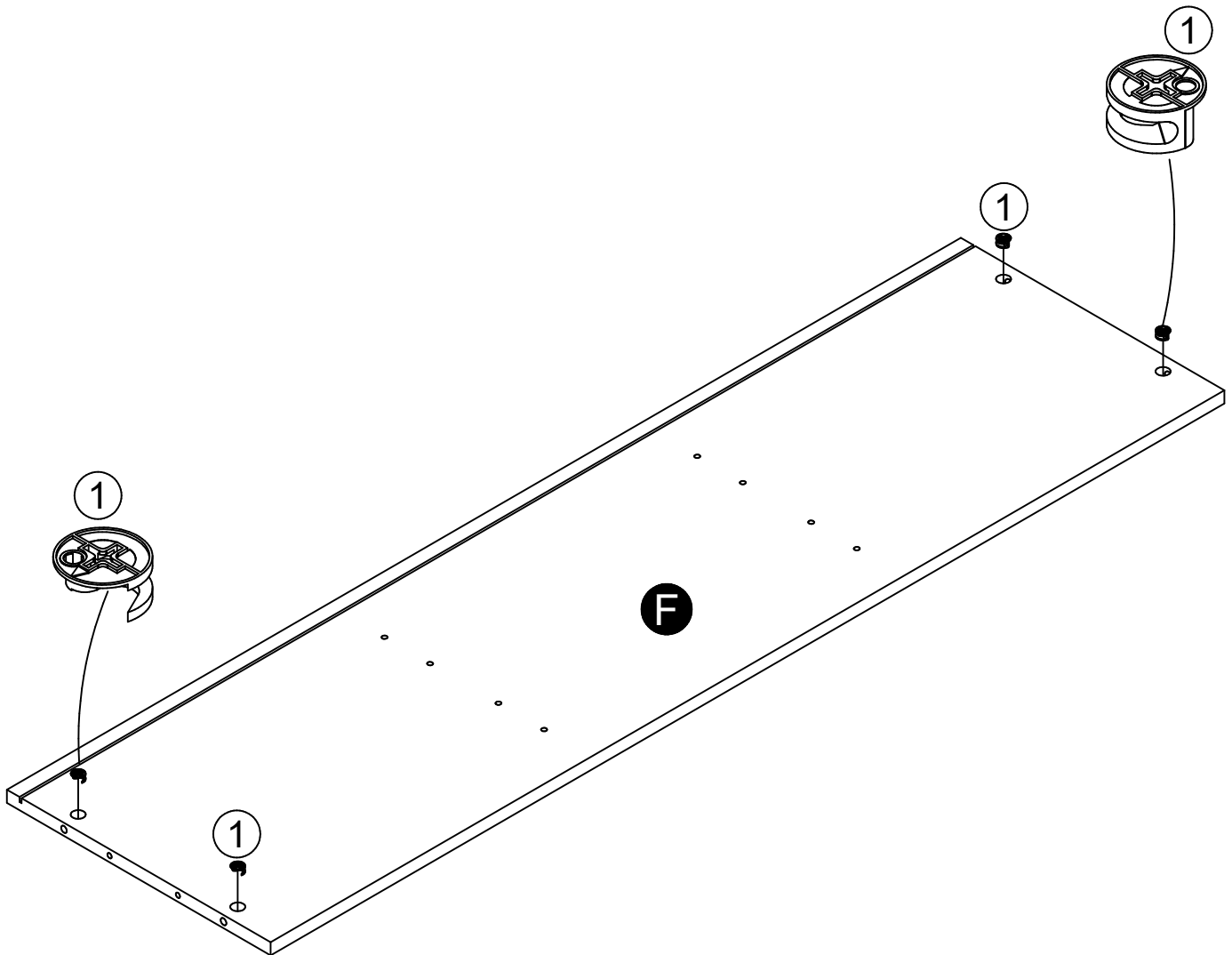

STEP 5

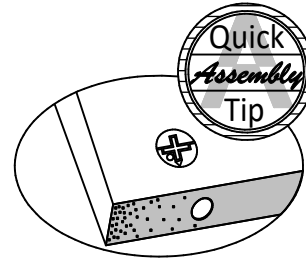

Proper orientation of CAM LOCK

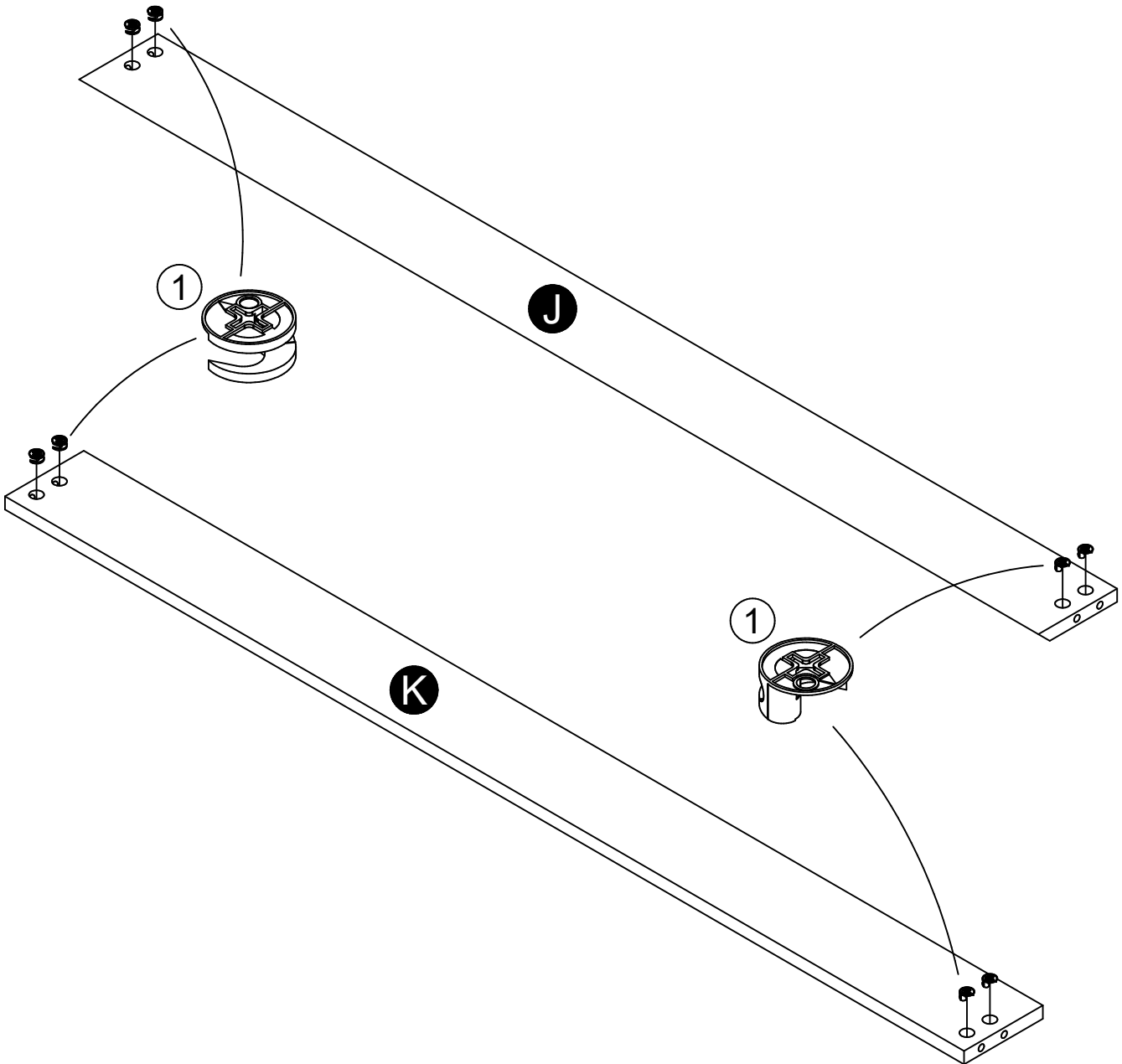

STEP 6

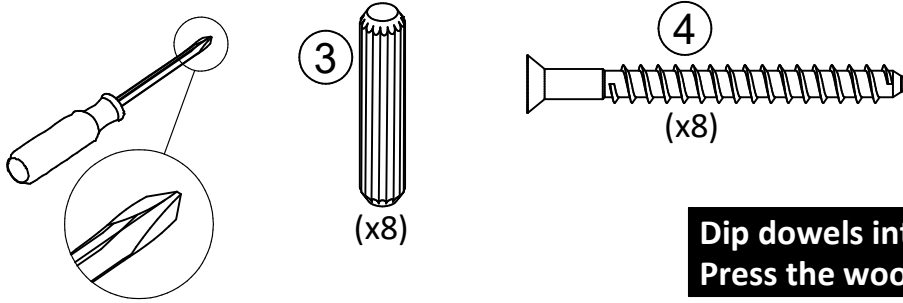

Dip dowels into water to active glue.
Press the wood dowels into holes as shown.

unfinished edges up

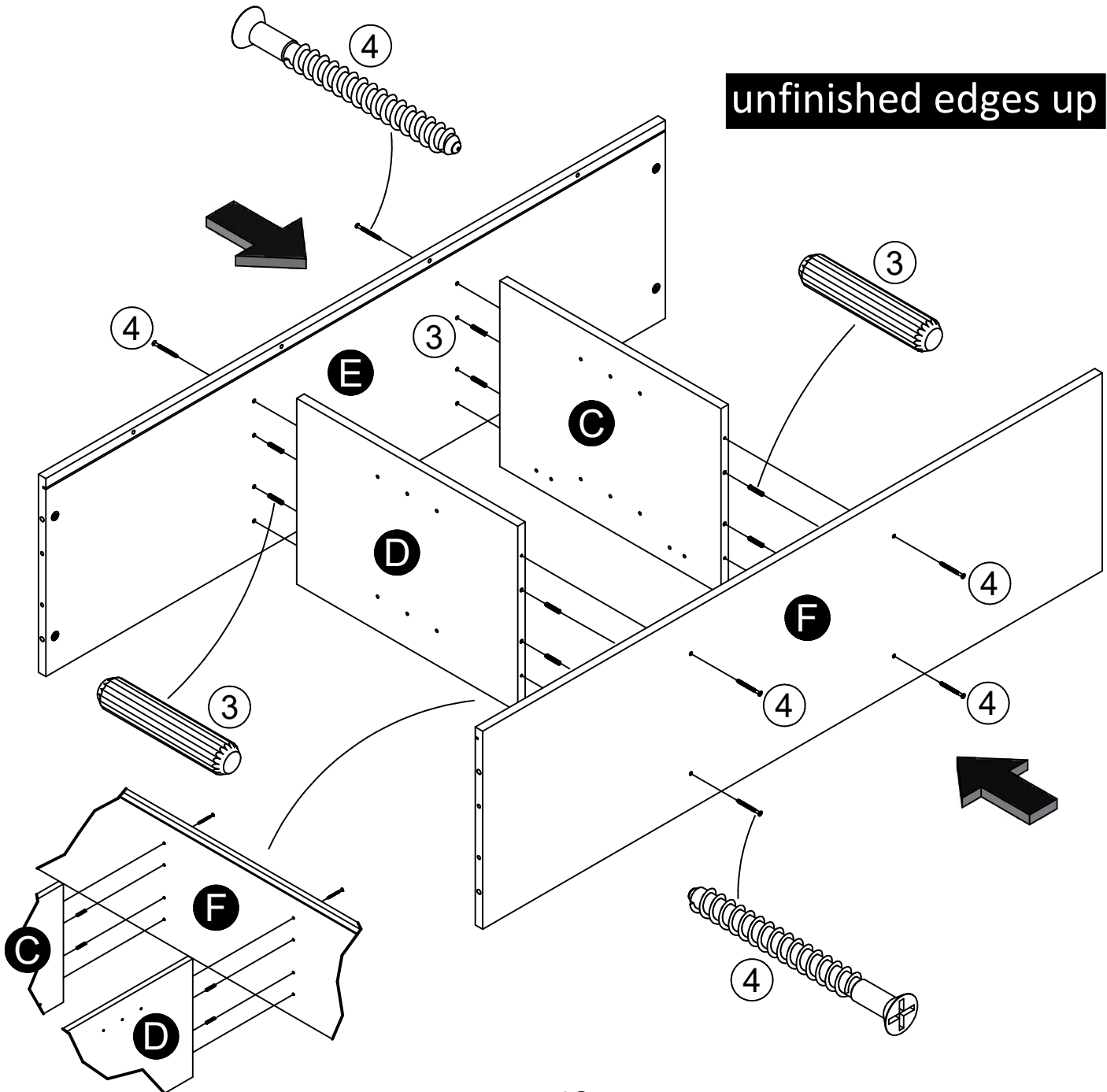

STEP 7

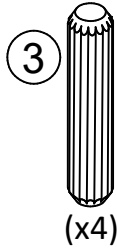
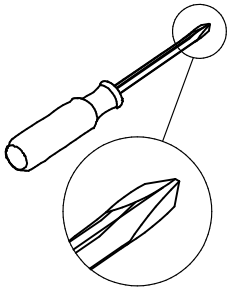

Dip dowels into water to active glue.
Press the wood dowels into holes as shown.

unfinished edges up

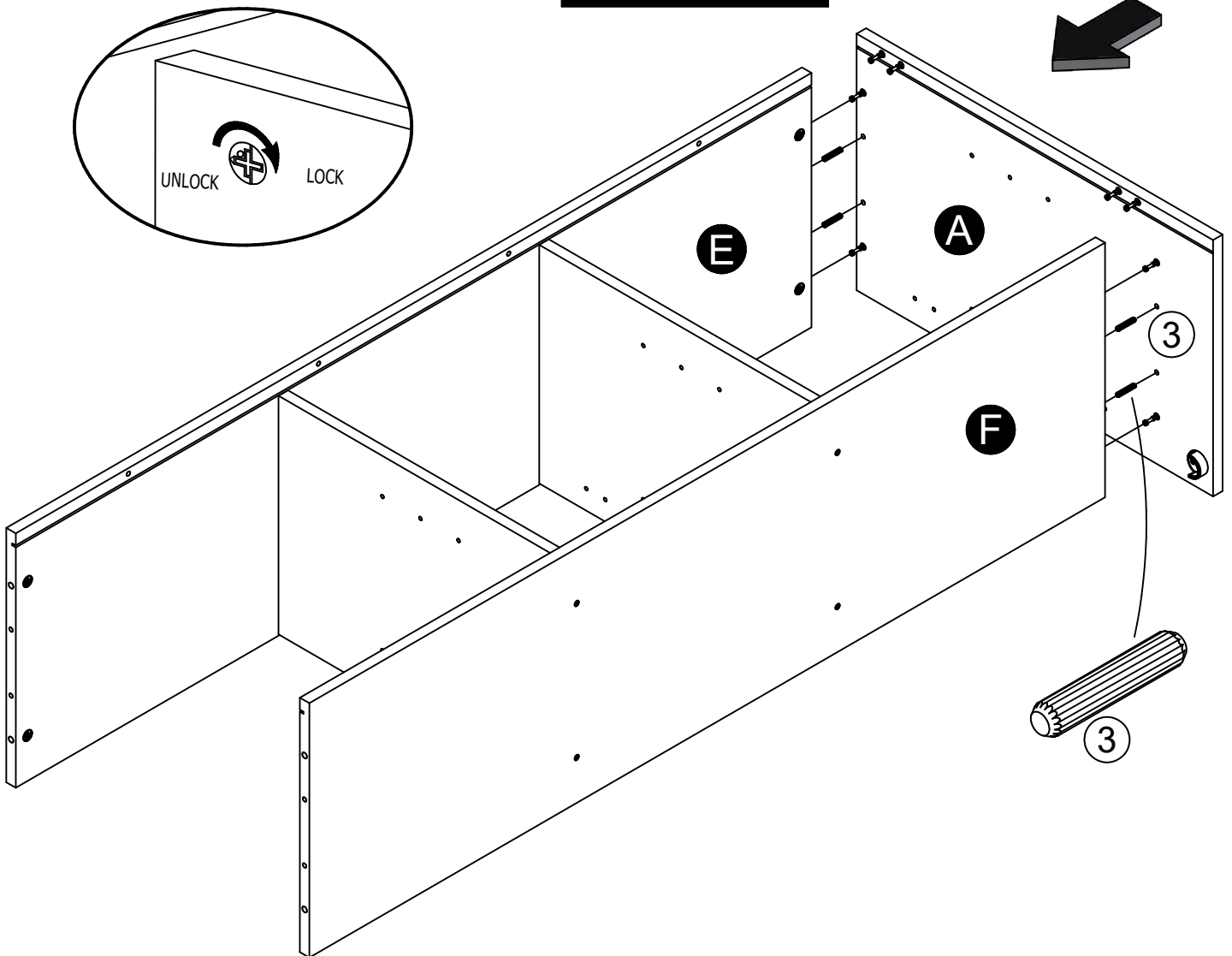

STEP 8

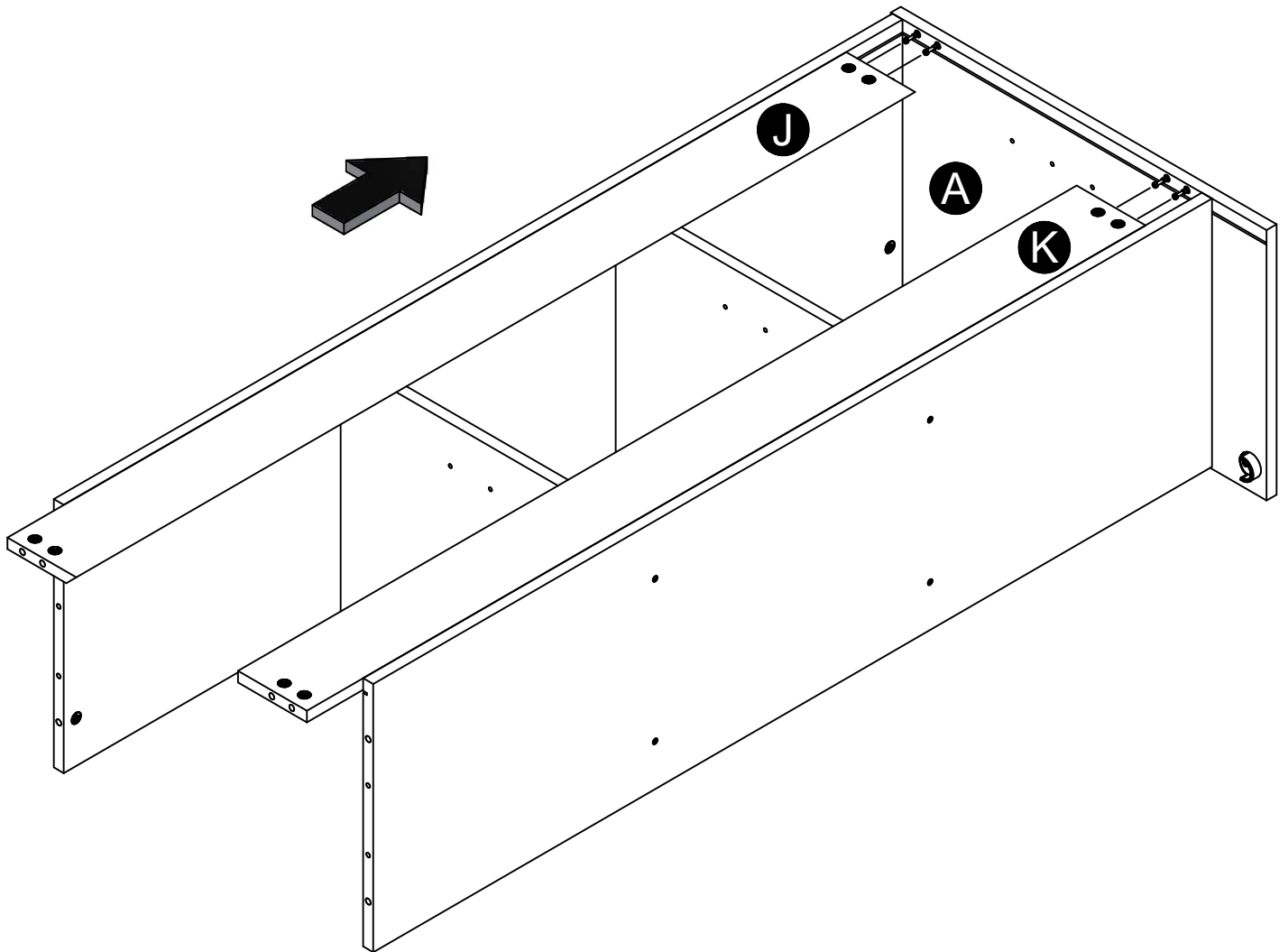
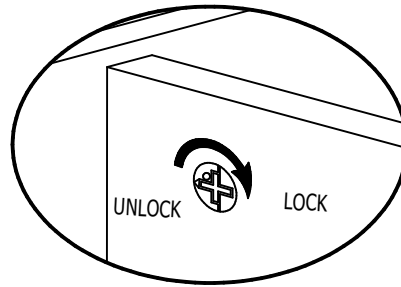
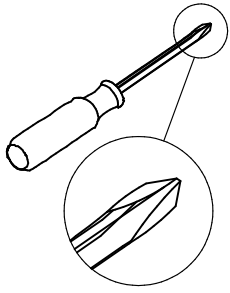

STEP 9

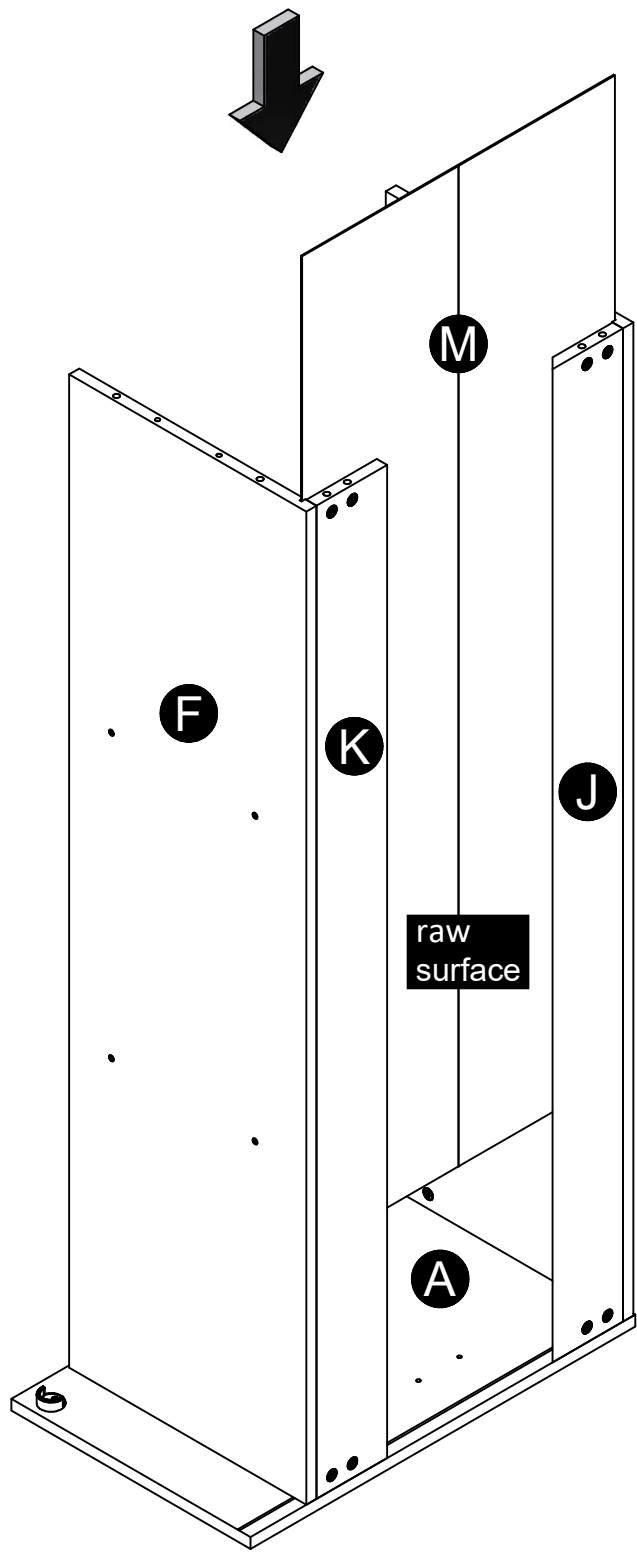

STEP 10

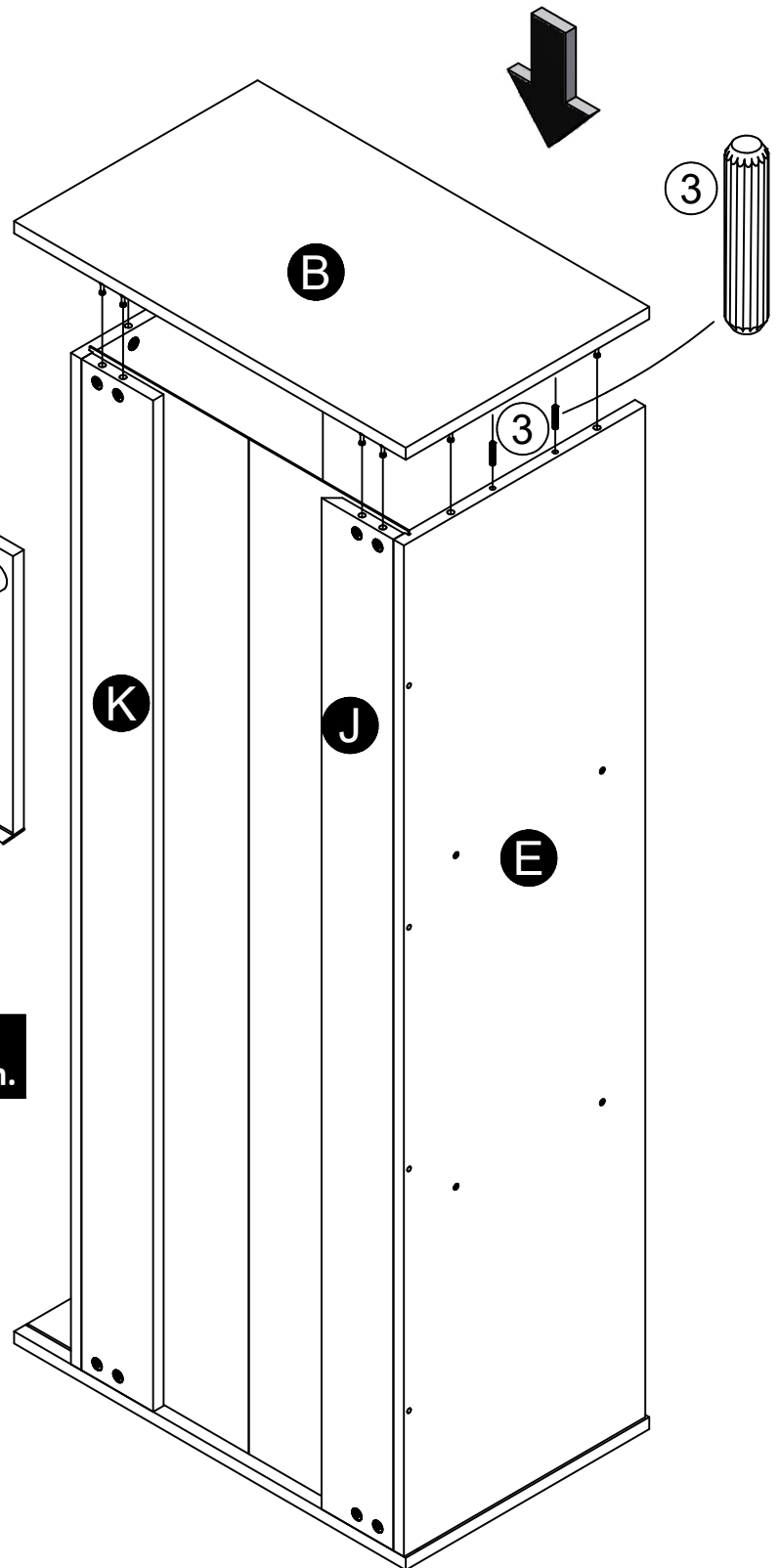
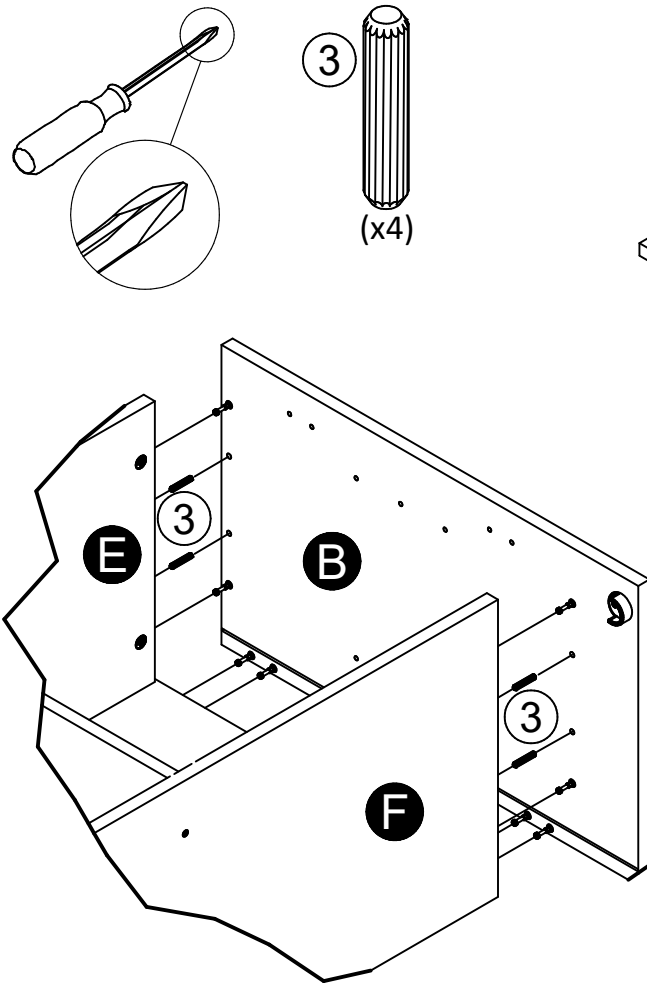

Dip dowels into water to activate glue.
Press the wood dowels into holes as shown.

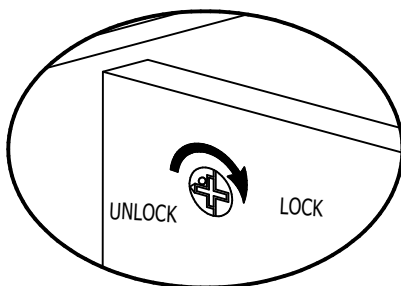

STEP 11

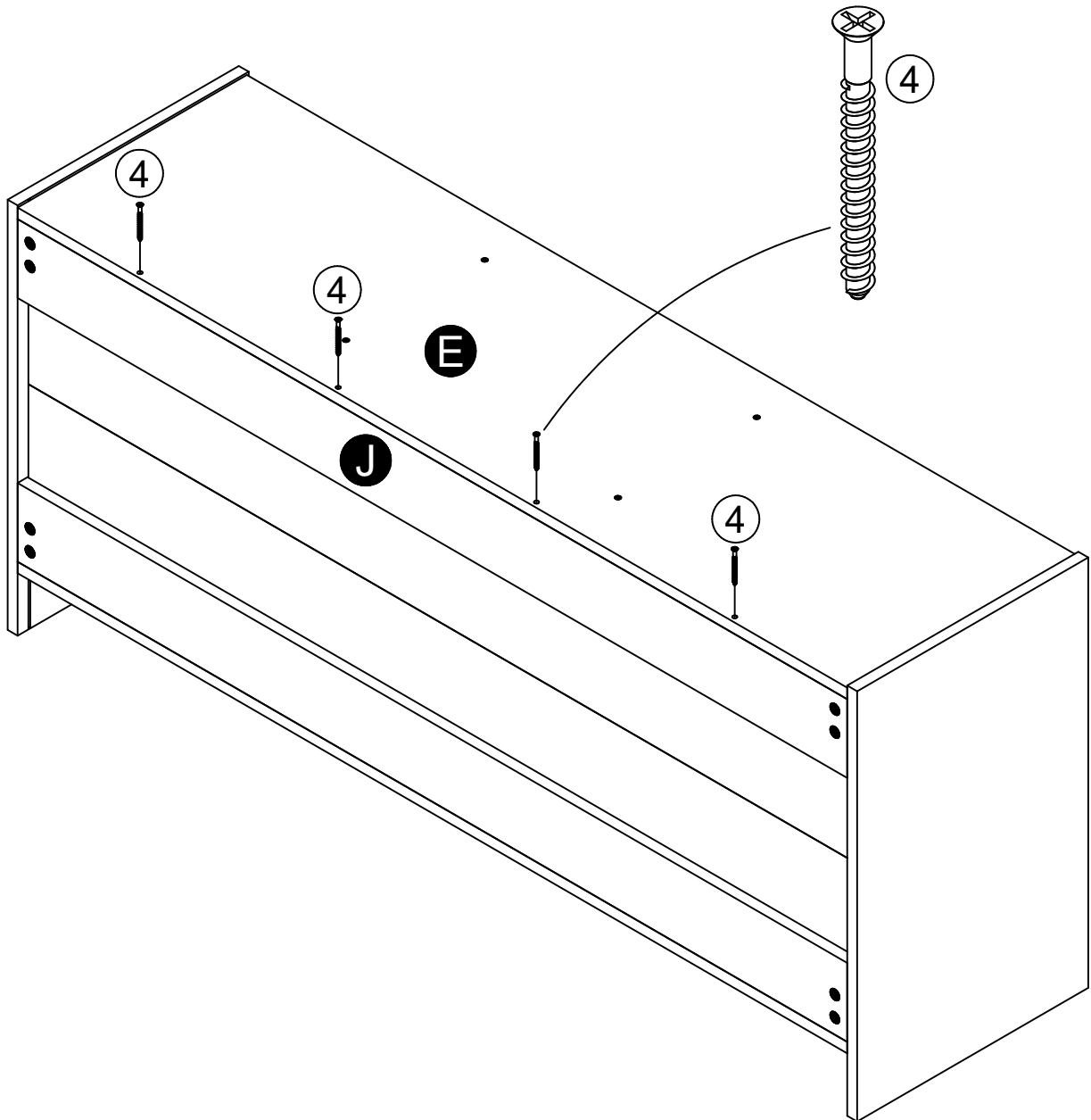
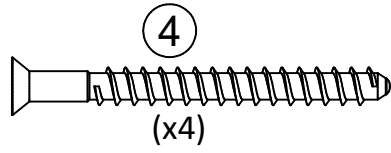
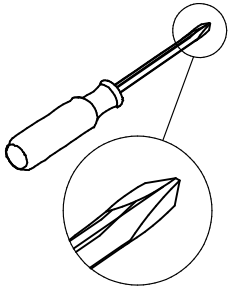

STEP 12

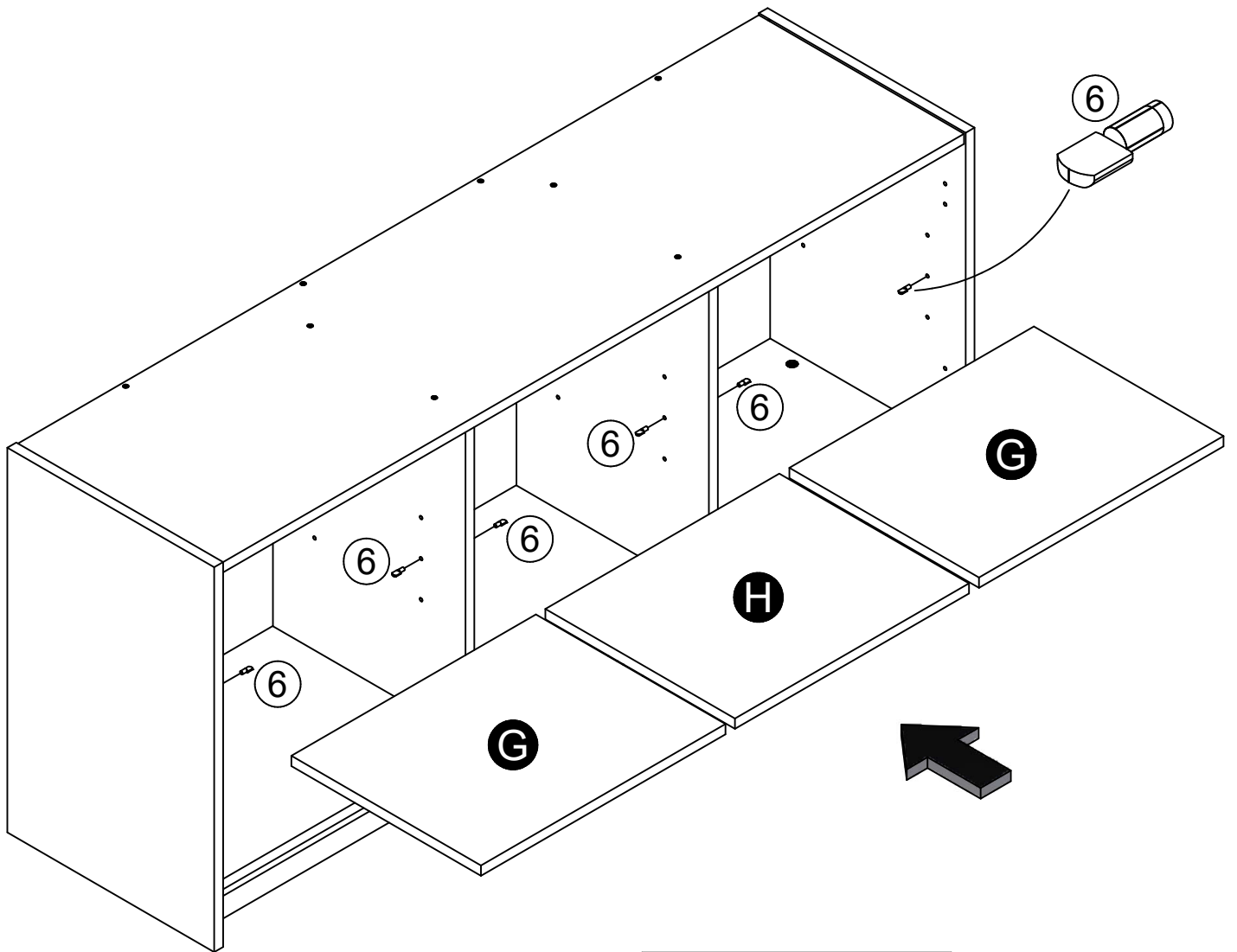
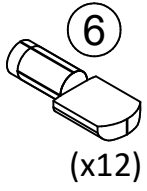

finished edges to front

STEP 13

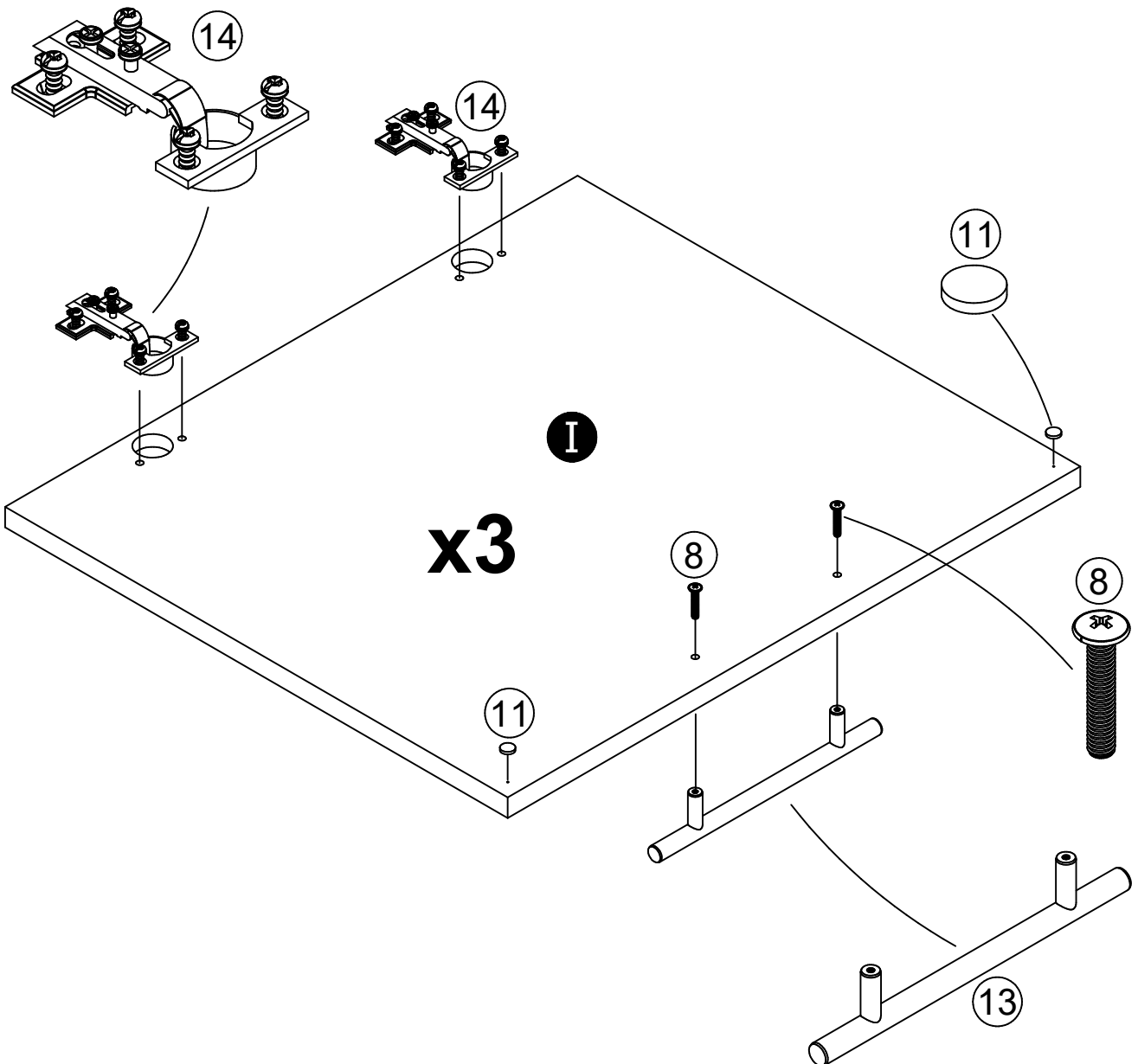
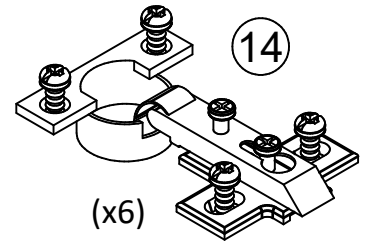
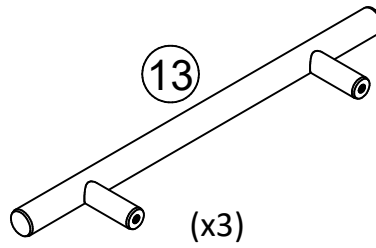
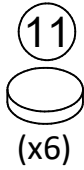
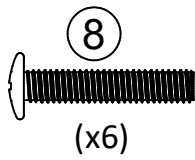
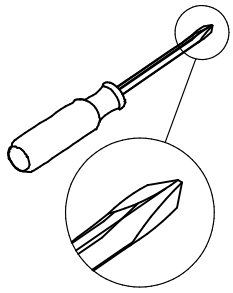

STEP 14

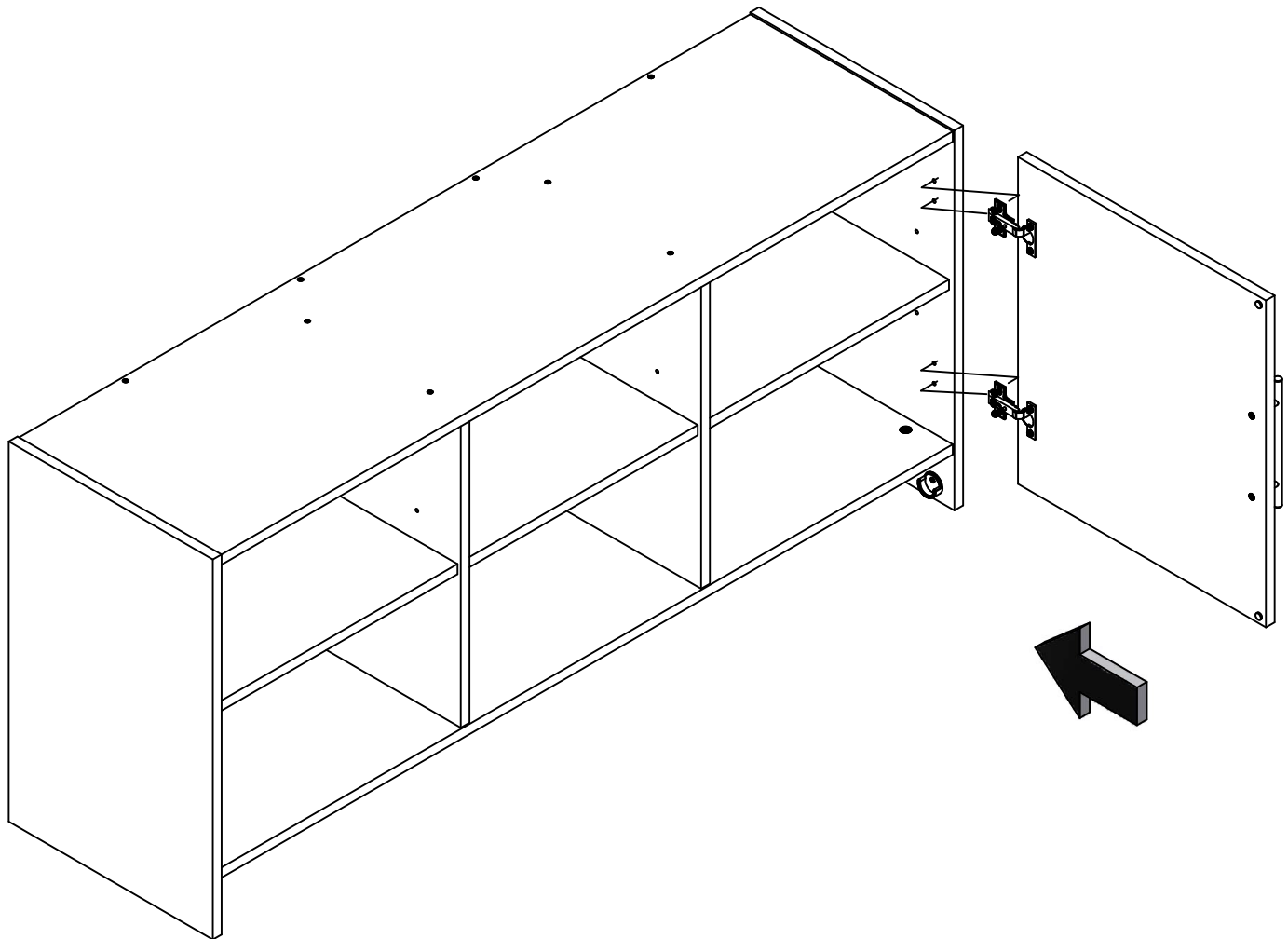
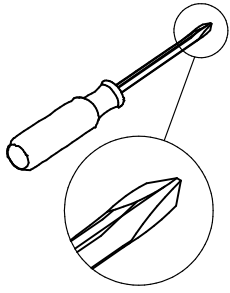

STEP 15

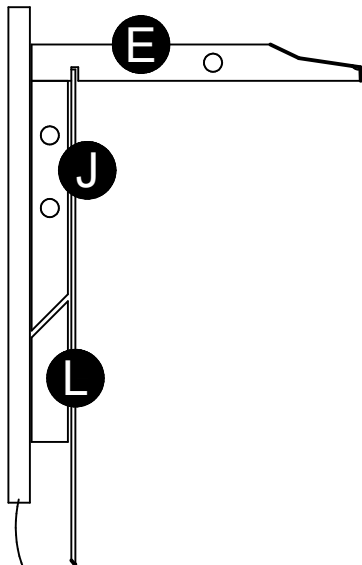
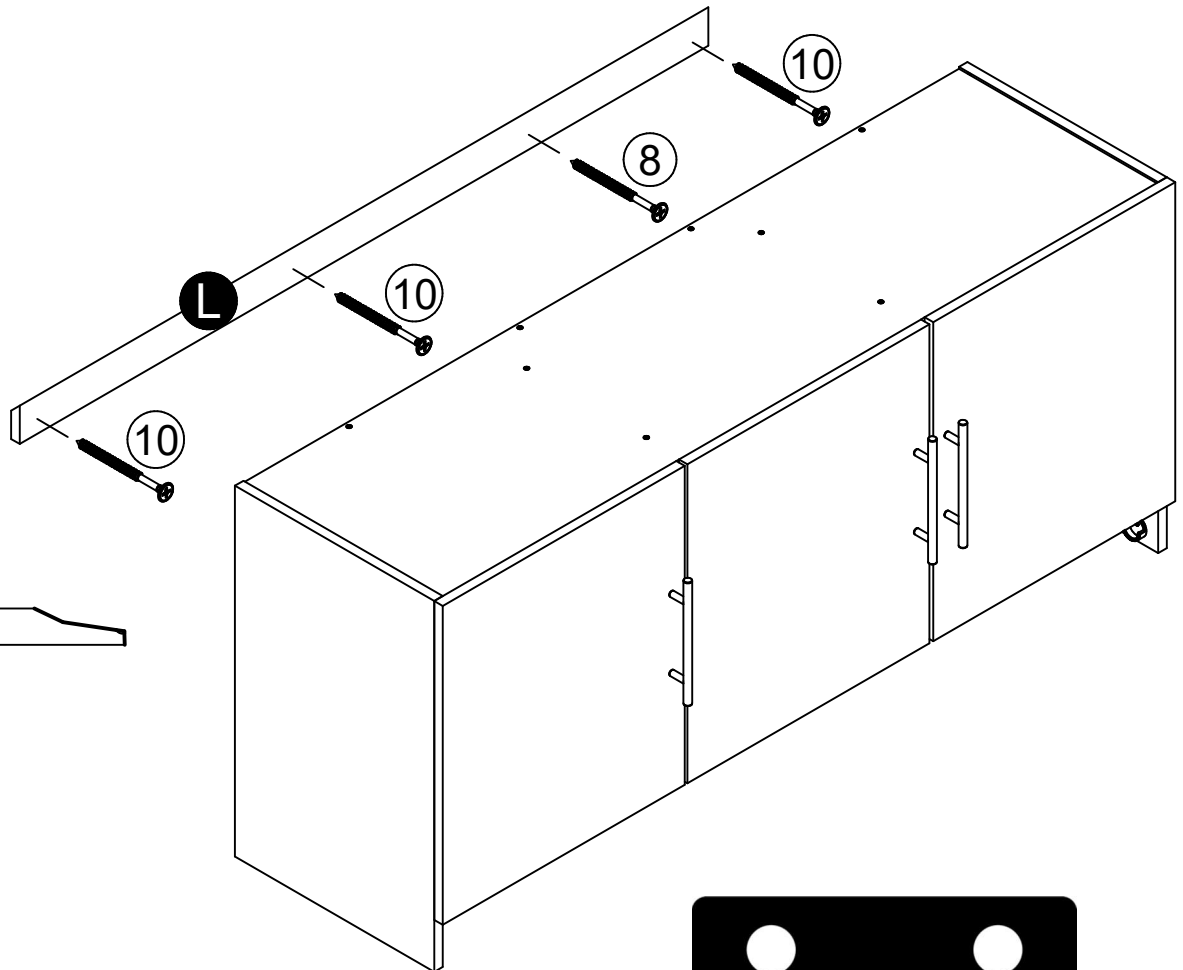
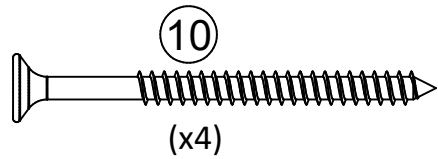
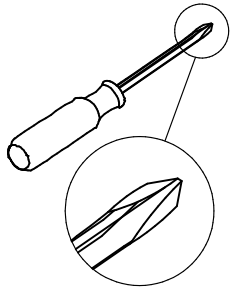

Wall to be mounted to.

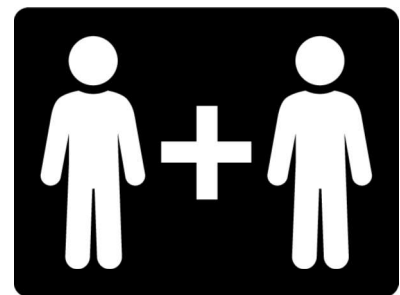

With the assistance of another person, locate and mark the studs in the wall that the cabinet will be mounted to. Mark the location of the studs with a pencil. Position the wall hanger (L) on the wall and mark the locations of the studs on the back rail. Drill two 3/16" diameter holes in the wall hanger (L) at the stud locations. Using a level, attach the wall hanger (L) to the wall with four screws (10) as shown. It is important that the wall hanger is mounted to a minimum of as least two studs. With the help of another person, place the assembled component onto the wall hanger (L) so the two beveled edges on the back rail (J) and wall hanger (L) mate together.

STEP 16

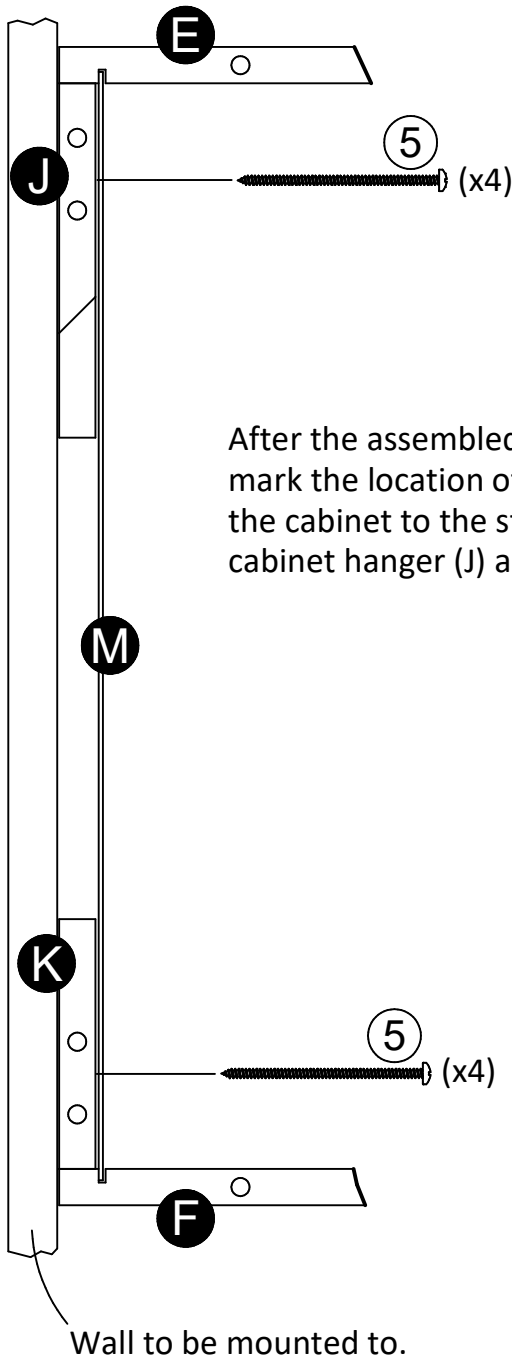
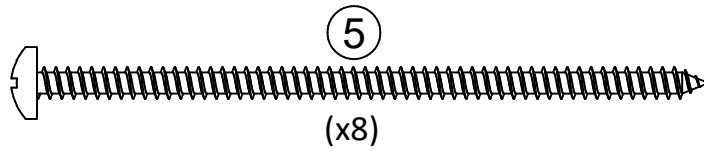
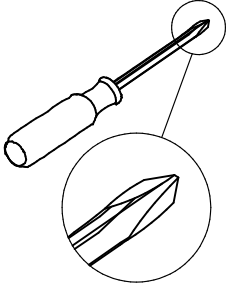

After the assembled component is placed onto the wall hanger, mark the location of the studs on the back panel (M). Fastening the cabinet to the studs by driving screws (5) through the cabinet hanger (J) and lower rail (K) as shown.

STEP 17

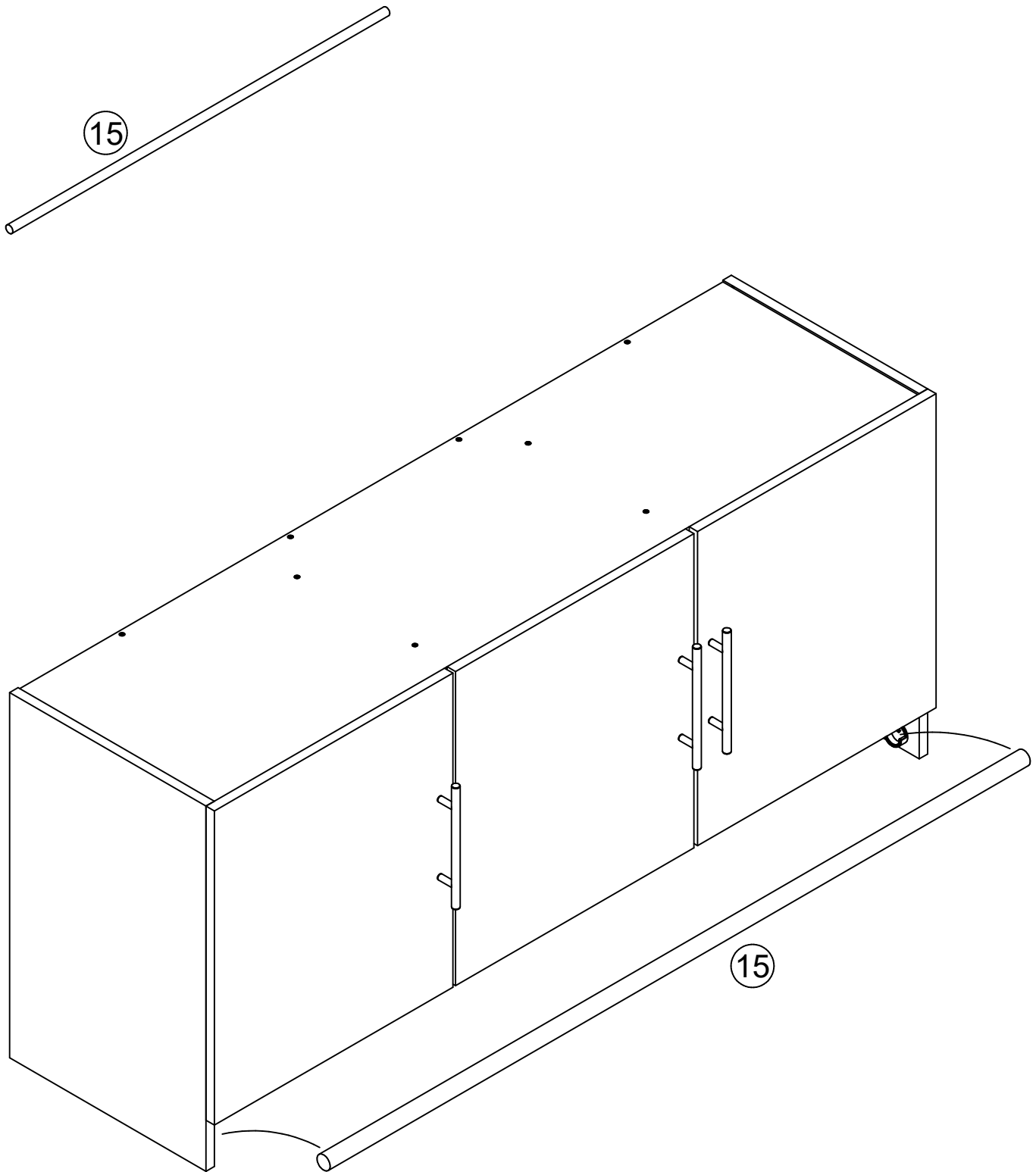

STEP 18

Door Adjustment

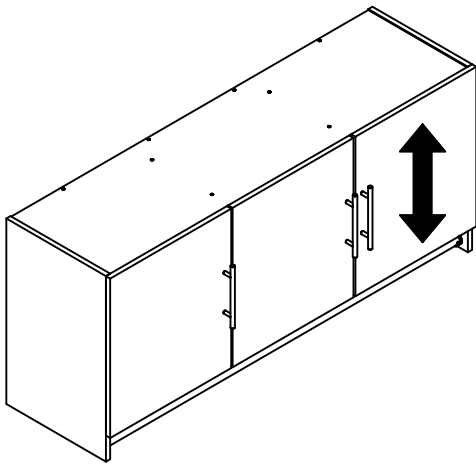
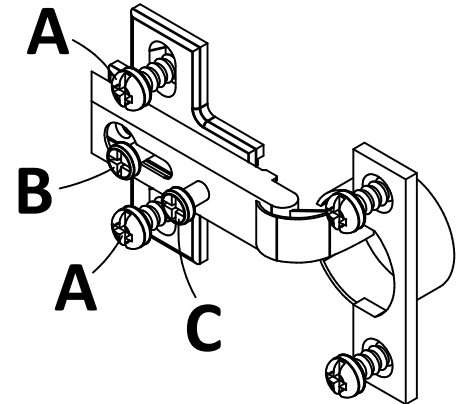
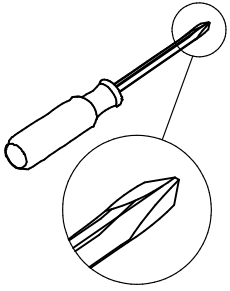

To adjust the vertical height:
Loosen the screws "A" on both hinges. They are usually in slotted holes which allows you to adjust up or down by a few mm. Then tighten back up.

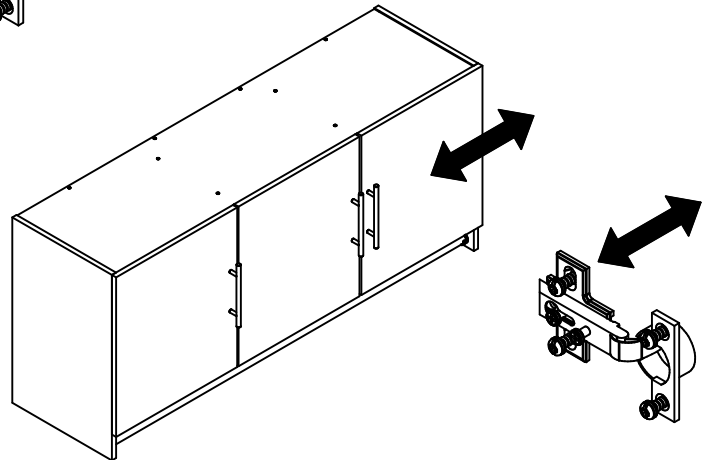
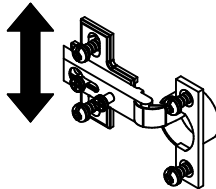

To adjust side to side:
Loosen the screw "C" on BOTH hinges and tighten "B" moves door outward. Loosen "B" and tighten "C" moves doors inward.

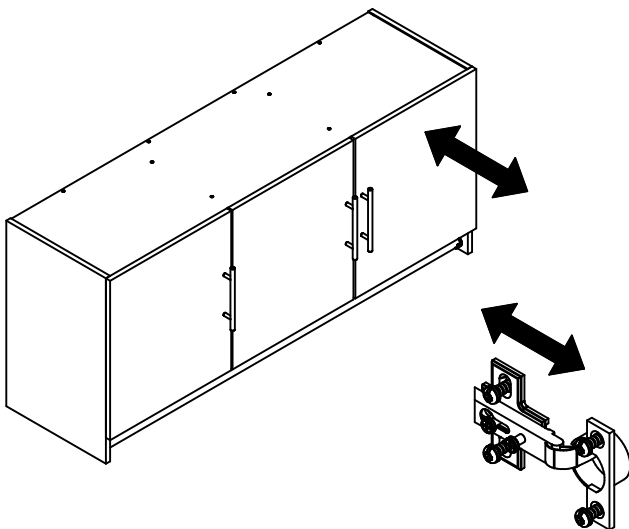

To adjust the depth:
Loosen the screw "B" and adjust door.

Maximum Loads

This unit has been designed to support the maximum loads shown. Exceeding these load limits could cause sagging, instability, product collapse, and/or serious injury.

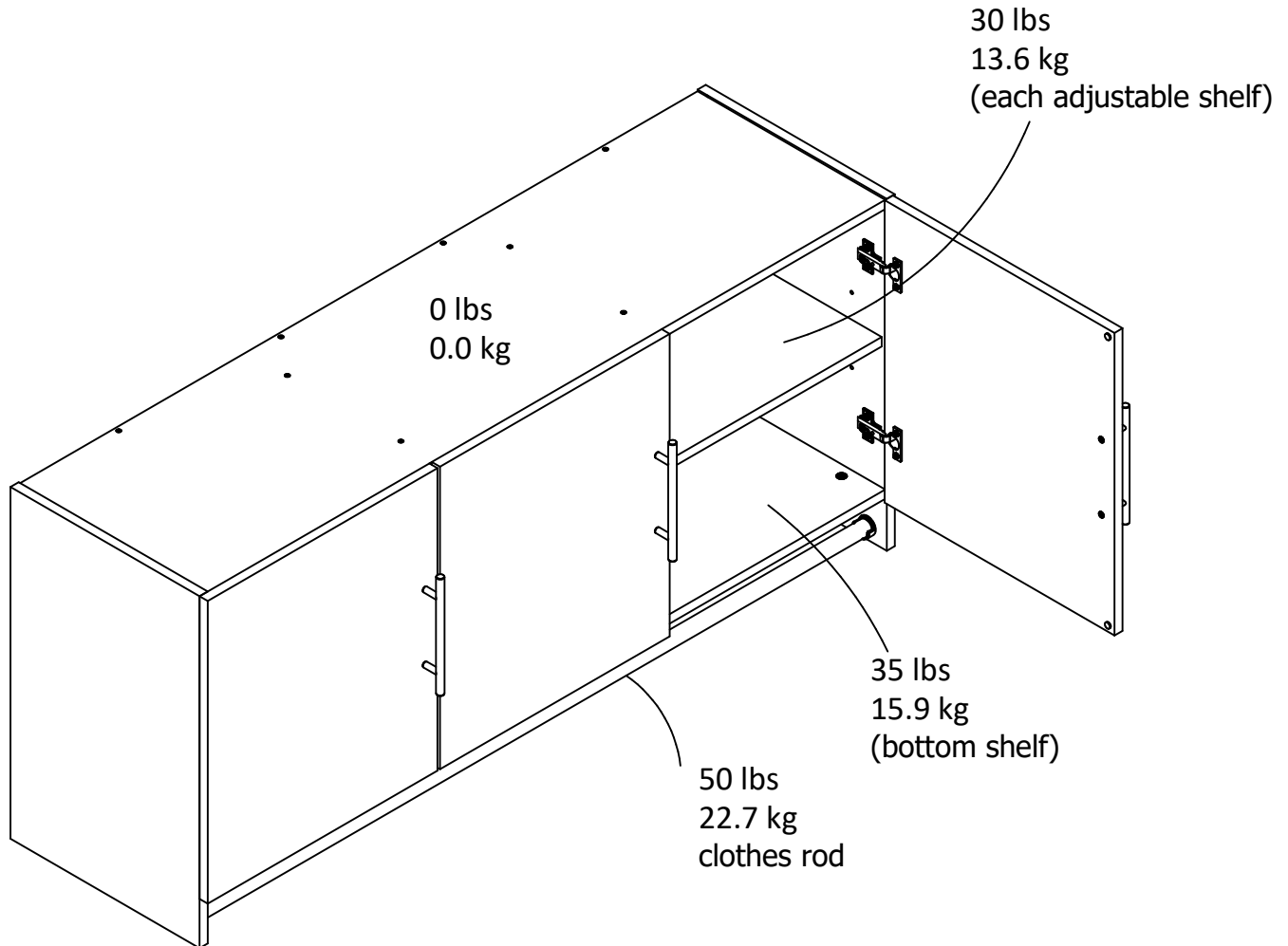

Warning: Risk of injury to persons - do not place a television on this furniture. This furniture is not approved for use with a television.

Certificate of Conformity

1. This certificate applies to the Dorel Home Furnishings, Inc. product identified by this instruction manual.
2. This certificate applies to compliance of this product with the CPSC Ban on Lead-Containing Paint (16 CFR 1303).
3. This product is distributed by: Dorel Home Furnishings, Inc.
410 East First Street South
Wright City, MO 63390
636-745-3351
4. Site of Manufacture: Tiffin OH
5. See front page of instruction manual for date of manufacture.

Register your product to receive the following:



- * New trend details - sneak peek on what's new
- * Surveys - have a voice within our community
- * Exclusive deals and discount codes
- * Quick and easy replacement part service

To register your product, visit systembuild.com

5 Star Rating



Visit your local retailer's website, rate your purchased product and leave us some feedback!

We would like to extend a big "Thank You" to all of our customers for taking the time to assemble this Systembuild product, and to give us your valuable feedback.

*Thank
You!*

Cubierta Delantera

Este libro de instrucciones contiene información **IMPORTANTE** de seguridad. Por favor lea y manténgalo para referencia en el futuro.

No Regrese este producto! Comuníquese con nuestro amigoso equipo de servicio al cliente para obtener ayuda.

Llámenos al: 1-866-452-4081 (Gratis) Lunes - Viernes 9am - 5pm CST

Visitar: www.systembuild.com

PRECAUCION

Este mueble puede volcarse y causar graves heridas y/o muerte.

Anclar el mueble a un poste de madera en la pared (si esto se requiere).

No Permita que los niños monten el mueble.

Mantenga los artículos más pesados en los cajones de abajo.

Consejos Útiles (página 2)

- Abra su artículo en el área donde usted planea utilizarlo para evitar levantar y moverlo menos
- Identificar, ordenar y contar las piezas antes de intentar ensamblar
- Las clavijas de compresión se golpean con un martillo
- Las diapositivas están marcadas con una R (derecha) y L (izquierda) para la colocación correcta
- Asegúrese de que siempre este el punto localizado en la parte superior de bloqueador de leva este volteado hacia borde exterior
- Utilizar todos los clavos para el panel de atrás y distribuirlos por igual
- El panel de atrás debe utilizarse para asegurarse de que la unidad quede fija y firme
- No use químicas fuertes ni limpiadores abrasivos en este artículo
- Nunca empuje, tire ni arrastre los muebles

Antes de Que Empieces (página 3)

- Lea cuidadosamente cada paso y siga el orden correcto
- Separar y contar todas sus piezas y hardware
- Dése suficiente espacio para el proceso de ensamble
- Tenga las siguientes herramientas: destornillador de cabeza plana, #2 cabeza Phillips
Destornillador y martillo
- Precaución: Si usa un taladro electrónico o un destornillador eléctrico para atornillar, por favor asegúrese que deje de atornillar cuando el tornillo este apretado. Fallar hacer esto puede causar barrer el tornillo.

Sistema de fijar el bloqueo de leva (página 3)

Esta sistema de fijar el bloqueo de leva sera usado en todo el proceso ensamble.

Página 22

Pared de la instalación.

Con la ayuda de alguien más, localice y marque los travesaños de la pared donde se instalará el gabinete. Marque la ubicación de los travesaños con un lápiz.

Coloque el soporte de pared (L) sobre la pared y marque la ubicación de los travesaños en el riel trasero. Taladre dos orificios de 3/16 de pulgada de diámetro en el soporte de pared (L) y sobre la ubicación de los travesaños. Con ayuda de un nivel, fije el soporte de pared (L) a la pared con cuatro tornillos (10) como se muestra. Es importante que el soporte de pared (L) esté instalado por lo menos sobre dos travesaños. Con la ayuda de alguien más, coloque el componente ensamblado en el soporte de pared (L) para que los dos bordes biselados del riel trasero (J) y el soporte de pared (L) se acoplen entre sí.

Página 23

Después de colocar el componente ensamblado en la percha de pared, marque la ubicación de los pernos en el panel posterior (M). Sujetar el gabinete a los pernos accionando tornillos (5) a través del colgador del gabinete (J) y el riel inferior (K) como se muestra.

Página 25

Para ajustar la altura vertical:

Afloje los tornillos "A" de ambas bisagras. Normalmente están en agujeros ranurados que le permitirán ajustar hacia arriba o hacia abajo unos pocos mm. A continuación, vuelva a apretarlos.

Para ajustar de lado a lado:

Si afloja el tornillo "C" de AMBAS bisagras y aprieta el "B", la puerta se mueve hacia fuera. Si afloja el tornillo "B" y aprieta el "C", la puerta se moverá hacia dentro.

Para modificar la profundidad:

Afloje el tornillo "B" y ajuste la puerta.

Página 26

CARGA MAXIMA

Esta unidad ha sido diseñada para soportar la carga máxima anotada. El exceder estos límites puede causar inestabilidad, colapsarse y/o causar serias lesiones.

ADVERTENCIA: Riesgo de lesiones a las personas - no coloque un televisor sobre muebles. Este mueble no está aprobado para su uso con un televisor.

Página 27

Registre su producto para recibir lo siguiente:

- * Detalles de nuevas tendencias - Vistazo a lo nuevo
- * Encuestas - alec su voz entre su comunidad
- * Códigos de ofertas y descuentos exclusivos
- * Fácil y rápido servicio de partes de remplazce

Para registrar su producto, visite systembuild.com

Clasificación de 5 estrellas

Visite el sitio web de su tienda local, califique su comprado y denos sus comentarios!

Nos gustaría enviar un gran "Agradecimiento" a todos nuestros clientes por tomarse el tiempo de ensamblar este producto de Systembuild, y por darnos sus valiosos comentarios.

Gracias

Couverture Avant

CE LIVRET D'INSTRUCTION CONTIENT DES INFORMATIONS **IMPORTANTES** SUR LA SÉCURITÉ. VEUILLEZ LIRE ET GARDER POUR UNE RÉFÉRENCE FUTURE

Ne retournez pas ce produit! Contactez notre équipe de service à la clientèle amicale d'abord pour obtenir de l'aide.

Appelez-nous: 1-866-452-4081 (sans frais) du Lundi au Vendredi de 9h à 17h Heure Centrale

Visitez: www.systembuild.com

ATTENTION

Le meuble peut basculer et causer des blessures graves ou la mort.

Ancrer le meuble à une planche murale dans le mur (si indiqué).

Ne laissez pas les enfants grimper sur le meuble.

Placez les articles lourds sur les étagères ou dans les tiroirs inférieurs.

Astuces Utiles (page 2)

-Ouvrez votre article dans la zone que vous prévoyez de le garder pour moins de levage lourd

-Identifier, trier et compter les pièces avant d'essayer d'assembler

-Les goujons de compression sont taraudés avec un Marteau

-Les glissières sont marquées d'un R (droit) et d'un L (gauche) pour un bon placement

-Assurez-vous toujours de faire face la pointe situé sur le haut de la Serrure de Came vers le bord extérieur

-Utiliser tous les clous fournis pour le panneau arrière et les répartir également

-Le panneau arrière doit être utilisé pour vous assurer que votre appareil est robuste

-N'utilisez pas de produits chimiques agressifs ou de nettoyeurs abrasifs sur cet appareil

-Ne jamais pousser, tirer, ou faire glisser votre meuble

Avant de Commencer (page 3)

-Lisez attentivement chaque étape et suivez le bon ordre

-Séparez et comptez toutes vos pièces et matériaux

-Donnez-vous suffisamment de place pour l'assemblage

-Avoir les outils suivants: tournevis à tête plate, #2 tournevis Phillips, et Marteau

-Attention: Si vous utilisez une perceuse électrique ou un tournevis électrique pour visser, veillez à ralentir et arrêter lorsque la vis est bien serrée. Le non-respect de cette consigne peut endommager la vis.

Système de Fixation de Came (page 3)

Ce Système de Fixation de Came sera utilisé tout au long de l'assemblage

Page 22

Mur à monter.

Avec l'aide d'une autre personne, localisez et marquez les montants du mur sur lesquels l'armoire sera montée. Marquez l'emplacement des montants avec un crayon.

Positionnez le support mural (L) sur le mur et marquez l'emplacement des montants sur le rail arrière. Percez deux trous de 3/16" de diamètre dans le support mural (L) à l'emplacement des montants. À l'aide d'un niveau, fixez le support mural (L) au mur avec quatre vis (10) comme indiqué. Il est important que le support mural soit monté sur au moins deux montants. Avec l'aide d'une autre personne, placez l'élément assemblé sur le support mural (L) de manière à ce que les deux bords biseautés du rail arrière (J) et du support mural (L) s'emboitent.

Page 23

Une fois le composant assemblé placé sur le cintre mural, marquez l'emplacement des goujons sur le panneau arrière (M). Fixer l'armoire aux goujons en entraînant des vis (5) à travers le cintre de l'armoire (J) et le rail inférieur (K) comme indiqué.

Page 25

Pour ajuster la hauteur verticale :

Desserrez les vis « A » sur les deux charnières. Ils sont généralement dans des trous oblongs ce qui vous permet de les ajuster vers le haut ou vers le bas de quelques mm. Puis resserrez-les.

Pour ajuster d'un côté à l'autre :

Desserrez la vis « C » sur les DEUX charnières et serrez « B » pour déplacer la porte vers l'extérieur. Desserrez la vis « B » et serrez la vis « C » pour déplacer la porte vers l'intérieur.

Pour ajuster la profondeur :

Desserrez la vis « B » et ajustez la porte.

Page 26

CHARGES MAXIMALES

Ce meuble a été conçu pour supporter les charges maximales indiquées. En excédant ces limites de charge, le meuble pourrait devenir instable, s'effondrer, et/ou causer des blessures graves.

AVERTISSEMENT : Risque de blessure corporelle - ne pas placer une télévision sur ce meuble. Ce meuble n'est pas approuvé pour une utilisation avec une télévision.

Page 27

Enregistrez votre produit pour recevoir les éléments suivantes:

- * Détails sur les nouvelles tendances - un aperçu sur les nouveautés
- * Sondages - avoir une voix au sein de notre communauté
- * Offres exclusives et codes promo
- * Service de pièces de rechange rapide et facile

Pour enregistrer votre produit, visitez systembuild.com

5 Étoiles

Visitez le site Web de votre détaillant local, évaluez votre produit acheté et laissez-nous quelques commentaires !

Nous tenons à offrir un grand "Merci" à tous nos clients pour avoir pris le temps d'assembler ce produit "Systembuild", et de nous donner vos commentaires précieux.

Merci